

Guided drives DGRF-C, Clean Design



Guided drives DGRF-C, Clean Design

Features and Product range overview



At a glance

- The guided drive is used wherever hygiene, ease of cleaning and resistance are important, predominantly in dry and splash zones in the food and packaging industry.
- Corrosion-resistant in harsh environmental conditions
- Easy-to-clean design
- NSF-H1 compliant lubrication
- Resistant to conventional cleaning agents
- For hygiene reasons, the threads on the end caps should be sealed with suitable blanking screws
- With a dry-running seal (A3), the cylinder will continue to function reliably even if the lubricant has been washed away due to frequent cleaning.

Areas of application:

- Bottling systems in the beverage industry
 - Labelling and palletising machines
- Milk processing
 - Filling ice cream and yoghurt containers, etc.
- Meat processing
- Confectionery production
- Bakery production
- Packaging industry
 - Food, pharmaceuticals, cosmetics, chemicals, beverages and tobacco

Mounting options

Underneath

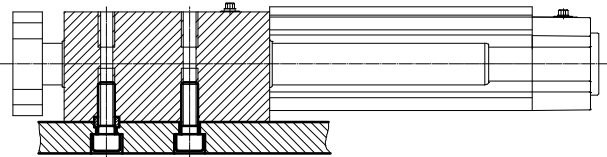

On top

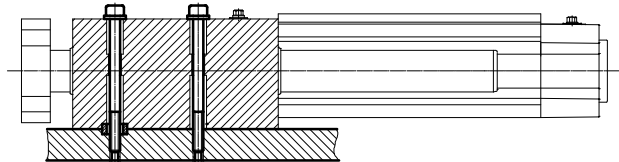

On the yoke plate

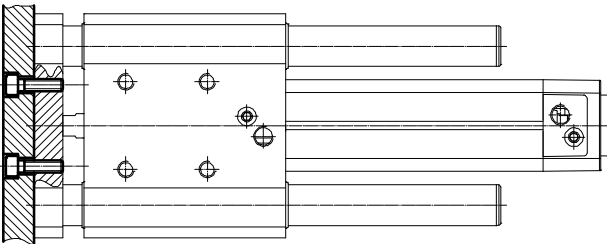

Product range overview

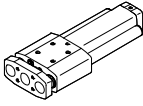
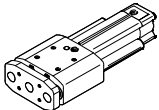
Function	Type	Piston Ø	Stroke	Cushioning			Position sensing	Mounting rail	Unlubricated operation
				P	PPV	PPS			
Double-acting	DGRF-C-GF								
		20, 25	10 ... 400	■	-	-	-	-	■
		32	10 ... 400	■	■	■	■	■	■
		40, 50, 63	10 ... 400	-	■	■	■	■	■

Guided drives DGRF-C, Clean Design

Peripherals overview

Piston \varnothing 20, 25

Piston \varnothing 32, 40, 50, 63

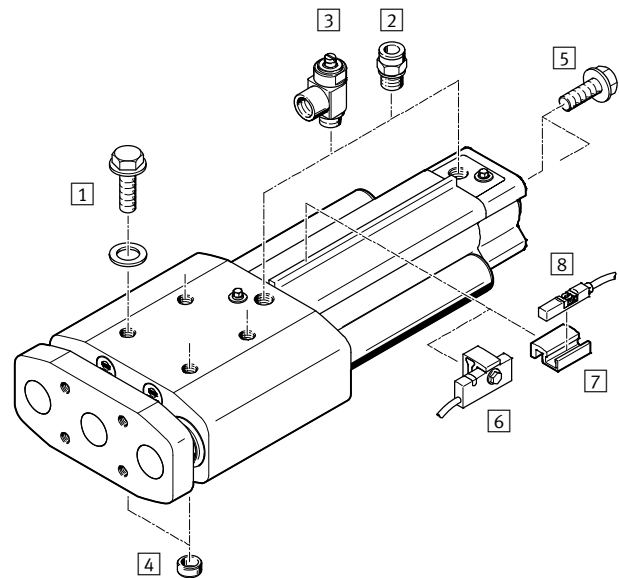
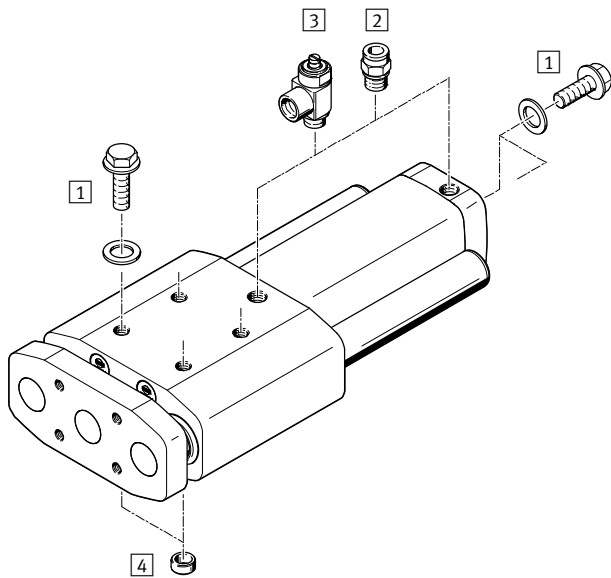

Accessories		Description	DGRF-...-			→ Page/ Internet
			P	PPV	PPS	
1	Plug screw DAMD	<ul style="list-style-type: none"> For sealing unused mounting threads The cover plate is included with the screw The screws are not included with the drive 	■	■	■	15
2	Push-in fitting NPQH/CRQS/CRQSL/NPQP	For connecting overall toleranced tubing	■	■	■	13
3	One-way flow control valve CRGRLA/VFOH	For regulating speed	■	■	■	14
4	Centring sleeve ZBH	<ul style="list-style-type: none"> For centring the guided drive Two centring sleeves are included in the scope of delivery 	■	■	■	15
5	Plug screw DAMD	<ul style="list-style-type: none"> For sealing unused mounting threads The screws are not included with the drive 	■	■	■	15
6	Proximity sensor SMT-C1	<ul style="list-style-type: none"> For sensing the piston rod position Proximity sensor is mounted on the sensor mounting rail 	■	■	■	12
7	Mounting kit SMB-8-C	<ul style="list-style-type: none"> For mounting the proximity sensor CRSMT-8M Mounting kit is mounted on the sensor mounting rail 	-	■1)	■	12
8	Proximity sensor CRSMT-8M	For sensing the piston rod position	-	■1)	■	12

1) Possible when ordering cylinders from 02/2014 (series E2).

Guided drives DGRF-C, Clean Design

Type codes

DGRF - C - GF - 32 - 200 - PPV - A - R - A3

Type	
Double-acting	
DGRF	Guided drive
Design	
C	Easy-to-clean design
Guide	
GF	Plain-bearing guide
Piston Ø [mm]	
32	
Stroke [mm]	
200	
Cushioning	
P	Elastic cushioning rings at both ends
PPV	Pneumatic cushioning, adjustable at both ends
PPS	Pneumatic cushioning, self-adjusting at both ends
Position sensing	
A	Via proximity sensor
Sensor mounting, external	
R	Mounting rail for proximity sensor
Wiper seal material	
-	Standard
A3	Suitable for unlubricated operation

Guided drives DGRF-C, Clean Design

Technical data

Function

P cushioning

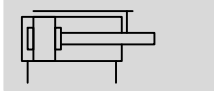

PPV cushioning

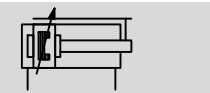

PPS cushioning

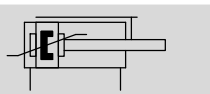

∅ - Diameter
20 ... 63 mm

— - Stroke length
10 ... 400 mm

 - www.festo.com



General technical data							
Piston ∅		20	25	32	40	50	63
Pneumatic connection		M5	M5	G1/8	G1/4	G1/4	G3/8
Mode of operation		Double-acting					
Design		Guide					
		Guide rods with yoke					
Guide		Plain-bearing guide					
Cushioning	P	Elastic cushioning rings at both ends			-		
	PPV	-		Pneumatic cushioning, adjustable at both ends			
	PPS	-		Pneumatic cushioning, self-adjusting at both ends			
Cushioning length	[mm]	-		20	20	22	22
Position sensing		-		Via proximity sensor			
Type of mounting		Via through-hole					
		Via female thread					
Mounting position		Any					
Torsional backlash ¹⁾	[°]	0.13	0.11	0.10	0.09	0.07	0.06

1) Retracted state, without load

Operating and environmental conditions							
Piston ∅		20	25	32	40	50	63
Variant				P	PPV/PPS		
Operating medium		Compressed air to ISO 8573-1:2010 [7:4:4]					
Note on operating/pilot medium		Lubricated operation possible (in which case lubricated operation will always be required)					
Operating pressure	[bar]	2.5 ... 10		2 ... 10	2 ... 12	2 ... 12	1.5 ... 12
	A3 [bar]	2 ... 10			2 ... 12	1.5 ... 12	
Ambient temperature	[°C]	-20 ... +80					
Food-safe ¹⁾		See supplementary material information					
Corrosion resistance class CRC ²⁾		3					

1) Additional information www.festo.com/sp → Certificates.

2) Corrosion resistance class CRC 3 to Festo standard FN 940070

High corrosion stress. Outdoor exposure under moderate corrosive conditions. External visible parts with primarily functional requirements for the surface and which are in direct contact with a normal industrial environment.

Guided drives DGRF-C, Clean Design

Technical data

Forces [N] and impact energy [J]						
Piston Ø	20	25	32	40	50	63
Theoretical force at 6 bar, advancing	189	295	483	754	1178	1870
Theoretical force at 6 bar, retracting	141	247	415	633	990	1682
Max. impact energy in the end positions with P cushioning	0.2	0.3	0.4	-	-	-

Permissible impact velocity

$$v_{perm.} = \sqrt{\frac{2 \times E_{perm.}}{m_{intrinsic} + m_{Load}}}$$

$v_{perm.}$ Permissible impact velocity

$E_{perm.}$ Maximum impact energy

$m_{intrinsic}$ Moving mass (drive)

m_{Load} Moving payload



Note

These specifications represent the maximum values that can be achieved. Note the maximum permissible impact energy.

Maximum permissible load:

$$m_{Load} = \frac{2 \times E_{perm.}}{v^2} - m_{intrinsic}$$

Weight [g]							
Piston Ø	20	25	32		40	50	63
			P	PPV/PPS			
Product weight with 0 mm stroke	885	1199	2090	2305	3000	4800	6405
Additional weight per 10 mm stroke	52	55	80	78	90	140	143
Moving mass with 0 mm stroke	417	486	902	904	1065	1792	2114
Moving mass per 10 mm stroke	38	38	58	58	65	102	102

Materials

Sectional view

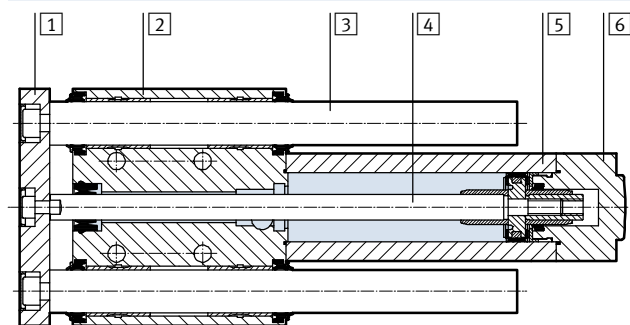

Guided drive	
1 Yoke plate	Anodised wrought aluminium alloy
2 Housing	Anodised wrought aluminium alloy
3 Guide rod	High-alloy stainless steel
4 Piston rod	High-alloy stainless steel
5 Cylinder barrel	Anodised wrought aluminium alloy
6 Cover	
DGRF-...-20/-25/-32-P	Anodised wrought aluminium alloy
DGRF-...-32-PPV/-PPS	Die-cast aluminium, coated
DGRF-...-40/-50/-63	Die-cast aluminium, coated
- Seal	
DGRF-...	TPE-U (PUR) media sealing (modified for resistance to hydrolysis and cleaning agents)
DGRF-...-A3	PE
Note on materials	RoHS-compliant

Guided drives DGRF-C, Clean Design

Technical data

Max. payload F as a function of stroke l

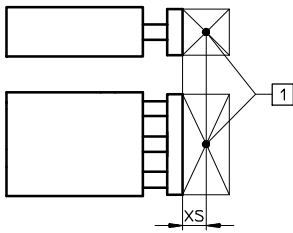

1 Centre of gravity of load

- Load data are based on a distance from the centre of gravity of XS = 50 mm
- Load data for larger distances on request

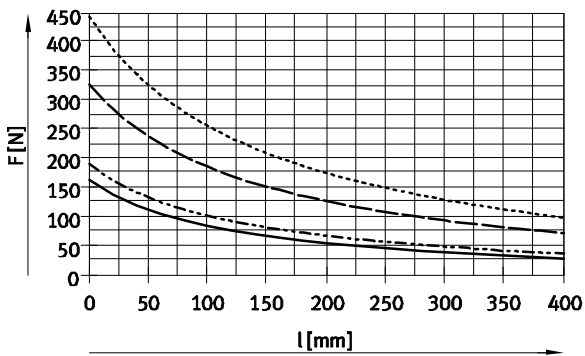

- Ø 20
- - - Ø 25
- · - · Ø 32/40
- · · · · Ø 50/63

Max. torque load M as a function of stroke l

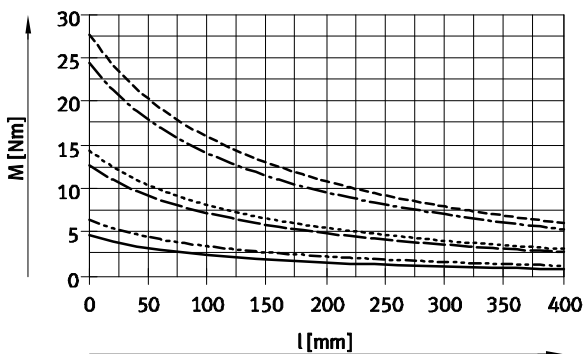
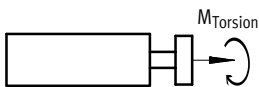

- Ø 20
- - - Ø 25
- · - · Ø 32
- · · · · Ø 40
- - - - - Ø 50
- - - - - Ø 63

Guided drives DGRF-C, Clean Design

Technical data

Deflection of piston rod

Deflection f_1 due to bearing clearance as a function of stroke l

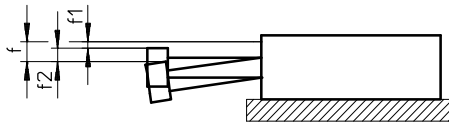

$$f = f_1 + f_2$$

f = Total deflection of piston rod

f_1 = Deflection due to bearing clearance

f_2 = Deflection due to lateral force

Deflection f_1 ,
due to bearing clearance as a function of stroke l

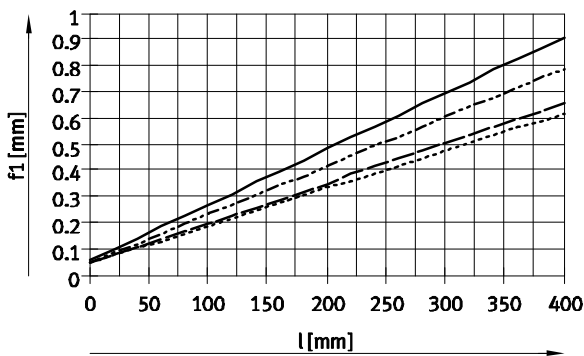

- $\varnothing 20$
- - - $\varnothing 25$
- · - $\varnothing 32/40$
- · · $\varnothing 50/63$

Deflection f_2 ,
due to useful load F and rigidity c as a function of stroke l

$$f_2 = \frac{F}{c}$$

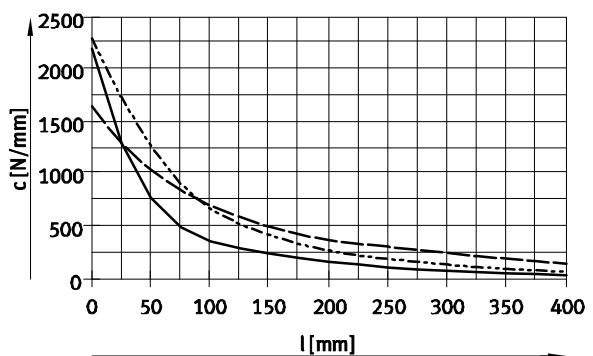

- $\varnothing 20/25$
- - - $\varnothing 32/40$
- · - $\varnothing 50/63$

End-position sensing

With proximity sensor SMT-C1

A minimum stroke is required to be able to sense both end positions at the cylinder.

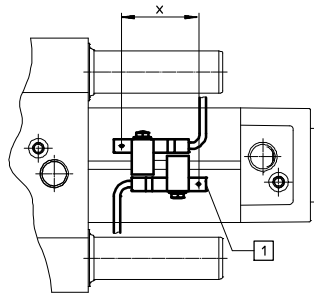

- 1 Position of the proximity sensor within the housing.

Piston \varnothing	32	40	50	63
Minimum stroke x [mm]	35	35	35	30

With mounting kit SMB-8-C and proximity sensor CRSMT-8M

A minimum stroke is required to be able to sense both end positions at the cylinder.

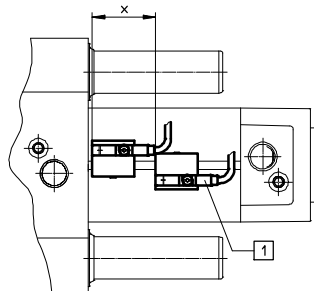

- 1 Position of the proximity sensor within the housing.

Piston \varnothing	32	40	50	63
Minimum stroke x [mm]	30	30	30	30

Guided drives DGRF-C, Clean Design

Technical data

FESTO

Dimensions

Download CAD data → www.festo.com

DGRF-...-P – elastic cushioning rings at both ends

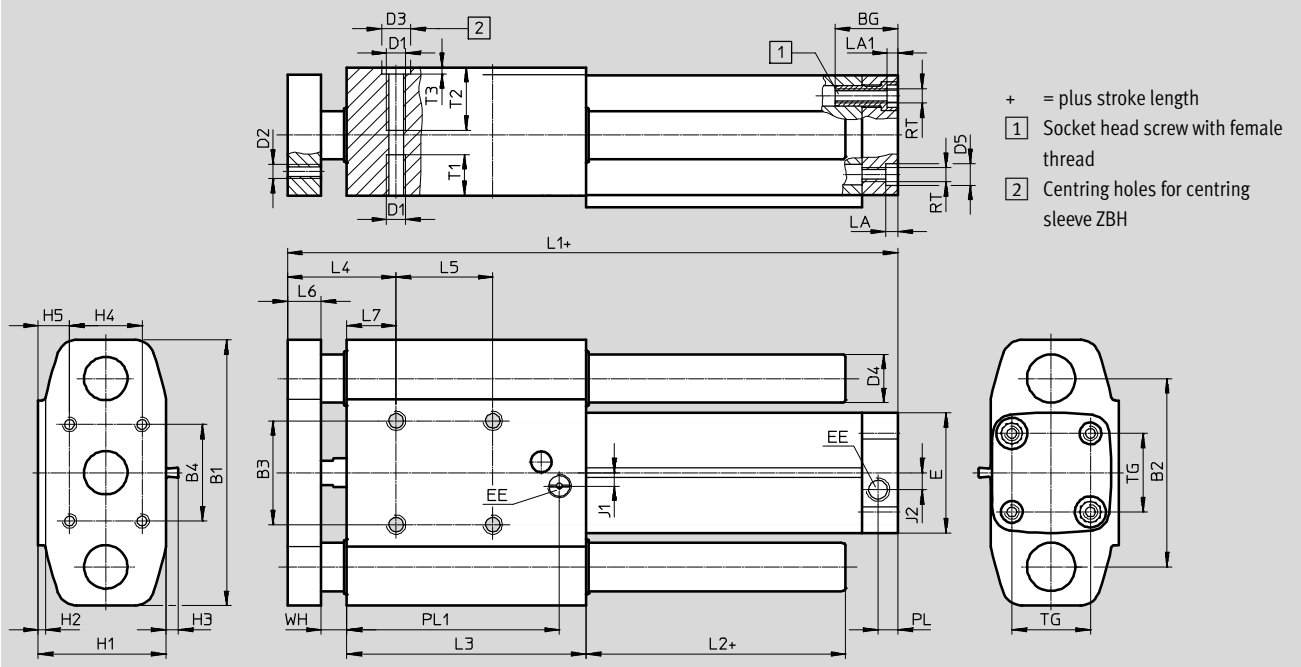

∅	BG	B1	B2	B3 ²⁾	B4	D1	D2	D3 ³⁾	D4	D5	E	EE
[mm]								∅ H7	∅	∅ F9		
20	19.5	83	58	30	30	M6	M5	9	16	9	37	M5
25	19.5	95	68	35	40	M6	M6	9	16	9	42	M5
32	26	110	78	43	40	M8	M6	12	20	9	50	G1/8

∅	H1	H2	H3 ¹⁾	H4	H5	J1	J2	L1	L2	L3	L4	L5
[mm]												
20	39	2	–	20	10.5	0	0	115 +1.4/-0.8	7	68	40 +1/-0.9	30
25	44	2	–	20	13	0	0	126 +1.4/-0.8	7	77	40 +1/-0.9	40
32	53	3	5	30	13	5.5	7	152.8 ±1.1	7.4	99	45 +0.9/-1	40

∅	L6	L7	LA	LA1	PL	PL1	RT	T1	T2	T3	TG	WH
[mm]												
20	12	18	4.9	4.6	6	62	M5	13	20	2.1	22	10 +0.5/-0.7
25	12	18	4.9	4.6	6	71	M5	13	25	2.1	26	10 +0.5/-0.7
32	14	20.4	5.1	4.6	8.2	88	M6	17	26	2.6	32.5	10.7 +0.3/-0.9

1) Only in combination with sensor mounting rail (DGRF-32-...-R)

2) Tolerance between centring holes ±0.02 mm

3) Two centring sleeves included in the scope of delivery

Guided drives DGRF-C, Clean Design

Technical data

Dimensions Download CAD data → www.festo.com

DGRF-...-PPV – pneumatic cushioning, adjustable at both ends
 DGRF-...-PPS – pneumatic cushioning, self-adjusting at both ends

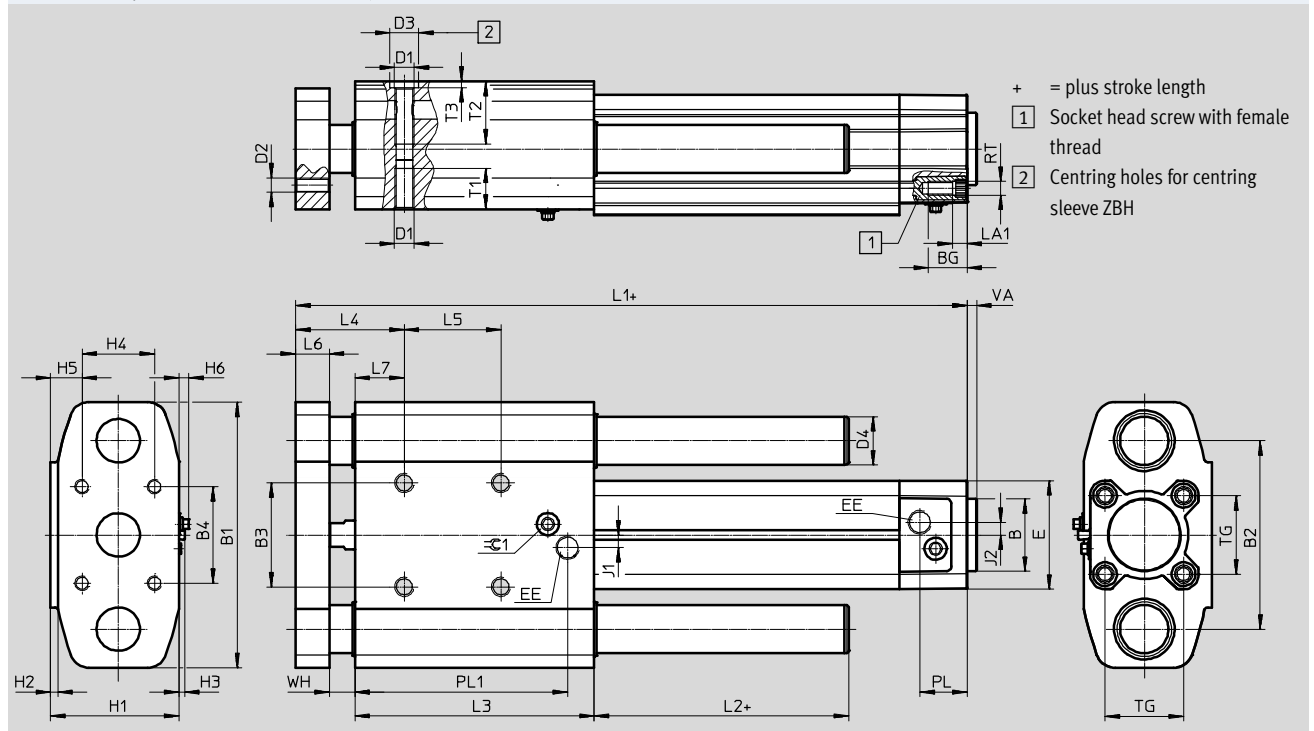

∅	B	BG	B1	B2	B3 ²⁾	B4	D1	D2	D3 ³⁾	D4	E	EE	H1	H2
[mm]	∅ d11								∅ H7	∅				
32	30	16	110	78	43	40	M8	M6	12	20	45	G1/8	53	3
40	35	16	120	88	51	50	M8	M6	12	20	54	G1/4	61	3
50	40	17	148	110	64	60	M8	M8	12	25	64	G1/4	73	3
63	45	17	162	125	80	80	M10	M8	12	25	75	G3/8	84	3

∅	H3 ¹⁾	H4	H5	H6	J1	J2	L1	L2	L3	L4	L5
[mm]											
32	2.5	30	13	5.6	5.3	5.3	177.6 +1.9/-1.2	7.4	99	45 +1.5/-1.1	40
40	3	30	17	5.6	4	4	183.5 +1.9/-1.3	7.5	99	45 +1.5/-1.1	40
50	2	40	18	7.5	5.5	5.5	193.5 +1.7/-1.3	7.7	105	50 +1.3/-1.2	40
63	2	40	23.5	9.3	6.3	6.3	207.3 +1.7/-1.3	7.5	105	50 +1.3/-1.2	40

∅	L6	L7	LA1	PL	PL1	RT	T1	T2	T3	TG	VA	WH	⊙ 1
[mm]													
32	14	20.4	5.6	19.5	88	M6	17	26	2.6	32.5	4	10.6 +1/-0.9	4
40	14	20.5	5.6	22.5	83	M6	17	26	2.6	38	4	10.5 ±1/-1	4
50	16	22.7	6.1	22.5	89	M8	17	20	2.6	46.5	4	11.3 +0.8/-1	4
63	20	18.5	6.1	27.5	88	M8	17	24	2.6	56.5	4	11.5 +0.8/-1	4

1) Only in combination with sensor mounting rail (DGRF-...-R)
 2) Tolerance between centring holes ±0.02 mm
 3) Two centring sleeves included in the scope of delivery

Guided drives DGRF-C, Clean Design

Ordering data – Modular products

Ordering table									
Size	20	25	32	40	50	63	Condi- tions	Code	Entry code
M Module No.	562216	562217	563366	562219	562220	562221			
Function	Guided drive							DGRF	DGRF
Product version	Easy-to-clean design							-C	-C
Guide	Plain-bearing guide							-GF	-GF
Piston Ø [mm]	20	25	32	40	50	63		-...	
Stroke [mm]	10 ... 400							-...	
Cushioning	Elastic cushioning rings at both ends							-P	
				Pneumatic cushioning, adjustable at both ends				-PPV	
				Pneumatic cushioning, self-adjusting at both ends				-PPS	
Position sensing				Via proximity sensor			<input type="checkbox"/>	A	
Sensor mounting, external				Mounting rail for proximity sensor			<input type="checkbox"/>	-R	
O Wiper seal variant	Standard								
	For unlubricated operation							-A3	

A, R Always included with piston Ø 32 ... 63.

Transfer order code

Guided drives DGRF-C, Clean Design

Accessories

With DGRF-...-PPV¹⁾/-PPS permissible:

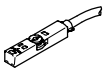

Ordering data – Proximity sensor for T-slot, magneto-resistive						Technical data → Internet: smt
	Type of mounting	Switching output	Electrical connection	Cable length [m]	Part No.	Type
N/O contact						
	Insertable in the slot from above, flush with the mounting kit	PNP	Cable, 3-wire	5.0	574380	CRSMT-8M-PS-24V-K-5,0-OE
			Cable, 3-wire	10.0	574381	CRSMT-8M-PS-24V-K-10,0-OE
			Plug M8x1, 3-pin	0.3	574383	CRSMT-8M-PS-24V-K-0,3-M8D
			Plug M12x1, 3-pin	0.3	574382	CRSMT-8M-PS-24V-K-0,3-M12

1) Possible when ordering cylinders from 02/2014 (series E2).

Ordering data – Mounting kit			
	Description	Part No.	Type
	For mounting the proximity sensor CRSMT-8M on the mounting rail	1806790	SMB-8-C

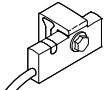





With DGRF-...-P/-PPV/-PPS permissible:

Ordering data – Proximity sensor for T-slot, magneto-resistive						Technical data → Internet: smt
	Type of mounting	Switching output	Electrical connection	Cable length [m]	Part No.	Type
N/O contact						
	Is mounted on the mounting rail	PNP	Cable, 3-wire	5.0	571339	SMT-C1-PS-24V-K-5,0-OE
			Plug M8x1, 3-pin	0.3	571342	SMT-C1-PS-24V-K-0,3-M8D
			Plug M12x1, 3-pin	0.3	571341	SMT-C1-PS-24V-K-0,3-M12

Ordering data – Connecting cables for SMT-C1-...					Technical data → Internet: nebu
	Electrical connection, left	Electrical connection, right	Cable length [m]	Part No.	Type
	Straight socket, M8x1, 3-pin	Cable, open end, 3-wire	2.5	541333	NEBU-M8G3-K-2.5-LE3
			5	541334	NEBU-M8G3-K-5-LE3
	Straight socket, M12x1, 5-pin	Cable, open end, 3-wire	2.5	541363	NEBU-M12G5-K-2.5-LE3
			5	541364	NEBU-M12G5-K-5-LE3
	Angled socket, M8x1, 3-pin	Cable, open end, 3-wire	2.5	541338	NEBU-M8W3-K-2.5-LE3
			5	541341	NEBU-M8W3-K-5-LE3
	Angled socket, M12x1, 5-pin	Cable, open end, 3-wire	2.5	541367	NEBU-M12W5-K-2.5-LE3
			5	541370	NEBU-M12W5-K-5-LE3

Guided drives DGRF-C, Clean Design

Accessories



Ordering data – Push-in fittings						Technical data → Internet: qs				
	Connection		Material	Weight [g]	Part No.	Type	PU ²⁾			
	Thread	Tubing O.D. Ø								
With external hexagon										
	M5	4	High-alloy stainless steel	4.2	1857681	NPCK-C-D-M5-K4	1			
		G1/8		6	14.1	1366257		NPCK-C-D-G18-K6		
	8			13.4	1490383	NPCK-C-D-G18-K8				
	G1/4	8		28.85	1691701	NPCK-C-D-G14-K8				
		10		32.9	1489336	NPCK-C-D-G14-K10				
	G3/8	10		51.15	1489614	NPCK-C-D-G38-K10				
	M5	4		Nickel- and chrome-plated brass	5.8	578334	NPQH-D-M5-Q4-P10	10		
		G1/8			6	11.2	578335		NPQH-D-M5-Q6-P10	
	G1/8				4	6.3	578338		NPQH-D-G18-Q4-P10	
		G1/8			6	9.2	578339		NPQH-D-G18-Q6-P10	
	G1/8		8		11.9	578340	NPQH-D-G18-Q8-P10			
		G1/4	6		13.1	578341	NPQH-D-G14-Q6-P10			
	G1/4		8		14.1	578342	NPQH-D-G14-Q8-P10			
		G1/4	10		17.5	578343	NPQH-D-G14-Q10-P10			
	G3/8		8		20.6	578345	NPQH-D-G38-Q8-P10			
		G3/8	10		22.7	578346	NPQH-D-G38-Q10-P10			
	G3/8		12		29.8	578347	NPQH-D-G38-Q12-P10			
			M5		4	Stainless steel	6.0		162860	CRQS-M5-4 ¹⁾
M5	6			8.4	162861		CRQS-M5-6 ¹⁾			
	R1/8		4	8.7	132643		CRQS-1/8-4			
R1/8			6	9.9	162862		CRQS-1/8-6			
	R1/8		8	12	162863		CRQS-1/8-8			
R1/4			6	18	132644		CRQS-1/4-6			
	R1/4		8	18	162864		CRQS-1/4-8			
R1/4			10	22	162865		CRQS-1/4-10			
	R3/8		10	29	162866		CRQS-3/8-10			
R3/8			12	37	162867		CRQS-3/8-12			
			R1/8	4	Polypropylene		2.5	133041	NPQP-D-R18-Q4-FD-P10	10
R1/8				6			3.0	133043	NPQP-D-R18-Q6-FD-P10	
		8		4.5		133045	NPQP-D-R18-Q8-FD-P10			
R1/4		6	3.5	133044		NPQP-D-R14-Q6-FD-P10				
		8	4.5	133046		NPQP-D-R14-Q8-FD-P10				
R1/4		10	7.0	133047		NPQP-D-R14-Q10-FD-P10				
		R3/8	10	8.0		133048	NPQP-D-R38-Q10-FD-P10			
R3/8			12	12.0		133049	NPQP-D-R38-Q12-FD-P10			
		With internal hexagon								
		M5	4	Nickel- and chrome-plated brass		4.5	578370	NPQH-DK-M5-Q4-P10	10	
	M5		6		8.8	578371	NPQH-DK-M5-Q6-P10			
		G1/8	4		6.2	578374	NPQH-DK-G18-Q4-P10			
	G1/8		6		9.1	578375	NPQH-DK-G18-Q6-P10			
		G1/8	8		12.8	578376	NPQH-DK-G18-Q8-P10			
	G1/4		8		14.4	578377	NPQH-DK-G14-Q8-P10			
		G1/4	10		18.6	578378	NPQH-DK-G14-Q10-P10			
	G3/8		12		28.2	578379	NPQH-DK-G38-Q12-P10			
	M5	4	Stainless steel	5	132328	CRQS-M5-4-1 ¹⁾	1			
		M5		6	7.7	132329		CRQS-M5-6-1 ¹⁾		
	R1/8			6	8.4	132330		CRQS-1/8-6-I		
		R1/8		8	12	132331		CRQS-1/8-8-I		
	R1/4			8	15	132332		CRQS-1/4-8-I		
		R1/4		10	21	132333		CRQS-1/4-10-I		
	R3/8			10	24	132334		CRQS-3/8-10-I		

1) With sealing ring
2) Packaging unit quantity



Guided drives DGRF-C, Clean Design

Accessories

FESTO

Ordering data – Push-in L-fittings					Technical data → Internet: qs					
	Connection		Material	Weight [g]	Part No.	Type	PU ²⁾			
	Thread	Tubing O.D. Ø								
With external hexagon										
	M5	4	Nickel- and chrome-plated brass	8.9	578276	NPQH-L-M5-Q4-P10	10			
		6		12.2	578277	NPQH-L-M5-Q6-P10				
	G1/8	4		16.3	578280	NPQH-L-G18-Q4-P10				
		6		19.3	578281	NPQH-L-G18-Q6-P10				
		8		22.2	578282	NPQH-L-G18-Q8-P10				
	G1/4	6		22.4	578283	NPQH-L-G14-Q6-P10				
		8		25.8	578284	NPQH-L-G14-Q8-P10				
		10		33.1	578285	NPQH-L-G14-Q10-P10				
		12		59.6	578286	NPQH-L-G14-Q12-P10				
	G3/8	8		36.7	578287	NPQH-L-G38-Q8-P10				
		10		38.2	578288	NPQH-L-G38-Q10-P10				
		12		58.2	578289	NPQH-L-G38-Q12-P10				
		M5		4	Stainless steel	12		162870	CRQSL-M5-4 ¹⁾	1
				6		18		162871	CRQSL-M5-6 ¹⁾	
		R1/8		4		14		132598	CRQSL-1/8-4	
6			19	162872		CRQSL-1/8-6				
8			26	162873		CRQSL-1/8-8				
R1/4		6	26	132599		CRQSL-1/4-6				
		8	30	162874		CRQSL-1/4-8				
		10	42	162875		CRQSL-1/4-10				
R3/8		10	49	162876		CRQSL-3/8-10				
		12	65	162877		CRQSL-3/8-12				
		R1/8	4	Polypropylene		4.0	133051	NPQP-L-R18-Q4-FD-P10	10	
			6			5.0	133053	NPQP-L-R18-Q6-FD-P10		
	8		7.0		133055	NPQP-L-R18-Q8-FD-P10				
	R1/4	6	5.5		133054	NPQP-L-R14-Q6-FD-P10				
		8	7.5		133056	NPQP-L-R14-Q8-FD-P10				
		10	12		133057	NPQP-L-R14-Q10-FD-P10				
	R3/8	10	13		133058	NPQP-L-R38-Q10-FD-P10				
		12	18		133059	NPQP-L-R38-Q12-FD-P10				

- 1) With sealing ring
- 2) Packaging unit quantity

Ordering data – One-way flow control valves					Technical data → Internet: crgrla		
	Connection		Material	Part No.	Type	PU ¹⁾	
	Thread	For push-in fitting					
	M5	CRQS/CRQSL/CRQST, QS	Electropolished stainless steel casting	161403	CRGRLA-M5-B	1	
	G1/8			161404	CRGRLA-1/8-B		
	G1/4			161405	CRGRLA-1/4-B		
	G3/8			161406	CRGRLA-3/8-B		
	G1/8	Push-in connector is integrated	Nickel-plated brass	578797	VFOH-LE-A-G18-Q4	1	
				578798	VFOH-LE-A-G18-Q6		
				578799	VFOH-LE-A-G18-Q8		
	G1/4			578800	VFOH-LE-A-G14-Q8		
				578801	VFOH-LE-A-G14-Q10		



- 1) Packaging unit quantity

Guided drives DGRF-C, Clean Design

Accessories

FESTO

Ordering data – Plastic tubing, standard O.D.		Technical data → Internet: tubing	
		Type	
	Approved for use in the food industry and resistant to hydrolysis	PUN-H	
	Good resistance to chemicals and hydrolysis	PLN	
	Pneumatic tubing with resistance to high temperatures and chemicals	PFAN	

Ordering data – Blanking screws, corrosion-resistant					
	For Ø	Description	Part No.	Type	PU ¹⁾
For mounting thread on the guide					
	20, 25	With cover plate	543715	DAMD-P-M6-12-R1	4
	32, 40, 50		543716	DAMD-P-M8-16-R1	
	63		543717	DAMD-P-M10-16-R1	
For mounting thread on the end cap					
	20, 25	With cover plate	543714	DAMD-P-M5-10-R1	4
	32 ²⁾		543715	DAMD-P-M6-12-R1	
	32 ³⁾ , 40	–	1355016	DAMD-PS-M6-12-R1	
	50, 63		650121	DAMD-PS-M8-16-R1	

- 1) Packaging unit quantity
- 2) For cylinder with P cushioning
- 3) For cylinder with PPV/PPS cushioning

Ordering data – Centring sleeves			Technical data → Internet: zbh	
	For Ø	Part No.	Type	PU ¹⁾
	20, 25	150927	ZBH-9	10
	32, 40, 50, 63	189653	ZBH-12	

- 1) Packaging unit quantity

Festo North America

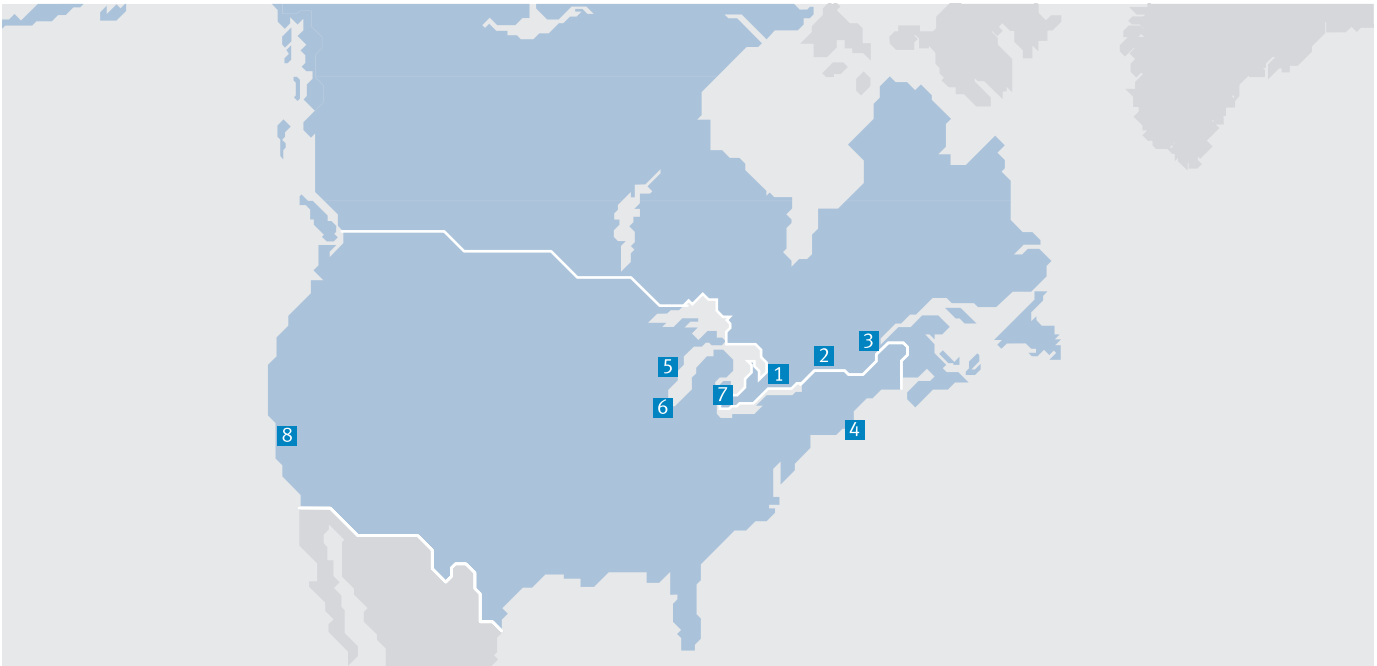

**1 Festo Canada
Headquarters
Festo Inc.**
5300 Explorer Drive
Mississauga, ON
L4W 5G4

2 Montréal
5600, Trans-Canada
Pointe-Claire, QC
H9R 1B6

3 Québec City
2930, rue Watt#117
Québec, QC
G1X 4G3



**4 Festo United States
Headquarters
Festo Corporation**
395 Moreland Road
Hauppauge, NY
11788

5 Appleton
North 922 Tower View Drive, Suite N
Greenville, WI
54942

7 Detroit
1441 West Long Lake Road
Troy, MI
48098

6 Chicago
85 W Algonquin - Suite 340
Arlington Heights, IL
60005

8 Silicon Valley
4935 Southfront Road, Suite F
Livermore, CA
94550

Festo Regional Contact Center

Canadian Customers

Commercial Support:
Tel: 1 877 GO FESTO (1 877 463 3786)
Fax: 1 877 FX FESTO (1 877 393 3786)
Email: festo.canada@ca.festo.com

Technical Support:
Tel: 1 866 GO FESTO (1 866 463 3786)
Fax: 1 877 FX FESTO (1 877 393 3786)
Email: technical.support@ca.festo.com

USA Customers

Commercial Support:
Tel: 1 800 99 FESTO (1 800 993 3786)
Fax: 1 800 96 FESTO (1 800 963 3786)
Email: customer.service@us.festo.com

Technical Support:
Tel: 1 866 GO FESTO (1 866 463 3786)
Fax: 1 800 96 FESTO (1 800 963 3786)
Email: product.support@us.festo.com

Subject to change

Internet: www.festo.com/us