

Planar surface gantries EXCH



# Planar surface gantries EXCH

Key features



## At a glance

### General

- Optimum dynamic response when compared with other Cartesian gantry systems
- The drive concept ensures low moving dead weight
- Flat system design
- Perfectly matched drive and controller package
- High acceleration in both axial directions

### Application examples

- Fast repositioning of parts and modules in a large, rectangular working space, e.g.:
  - Sorting
  - Loading and unloading
  - Gluing and cutting

## Operational principle

A slide is moved in a two-dimensional space (X/Y-axis) via a toothed belt. The system is powered by 2 fixed motors. The motors are coupled to the

toothed belt. The belt is guided via pulleys so that the slide can move to any position in a working space when the motors are actuated accordingly.

When using attachment components, additional processes can be carried out by independent Z-axes.

		Motor 1		
		+	•	-
Motor 2	+	→	↘	↓
	•	↗	•	↖
	-	↑	↖	←

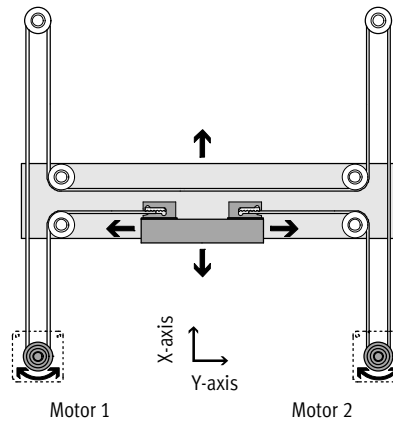

Type		EXCH-40	EXCH-60
Guide		Recirculating ball bearing guide	
Stroke of the			
X-axis	[mm]	200 ... 2000	500 ... 2500
Y-axis	[mm]	200 ... 1000	500 ... 1500
Z-axis	[mm]	50, 100, 150, 200	
Rated load for max. dynamic response <sup>1)</sup>	[kg]	4	6
Max. speed			
Horizontal	[m/s]	5	5
Vertical	[m/s]	4	3
Max. acceleration			
Horizontal	[m/s <sup>2</sup> ]	50	
Vertical	[m/s <sup>2</sup> ]	30	
Repeat accuracy <sup>2)</sup>	[mm]	±0.1	
Mounting position <sup>3)</sup>		Vertical or horizontal	

1) Rated load = tool load (attachment component (Z-axis) + gripper, for example) + payload

2) The repeat accuracy relates to the centre point of the slide

3) Vertical mounting position only permitted with motors with brake and braking resistors

# Planar surface gantries EXCH

Key features

## Motor attachment variants

EXCH-...-B – Motor underneath

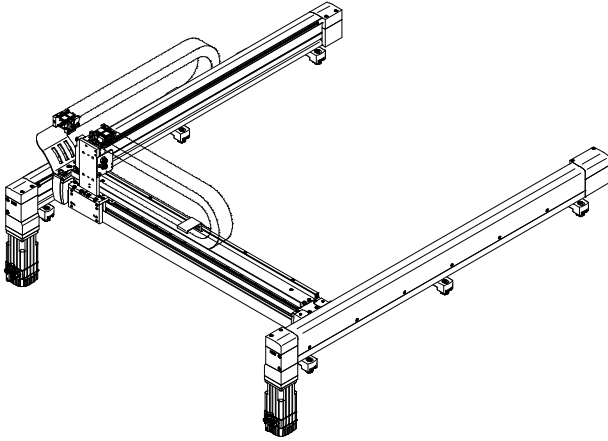

EXCH-...-T – Motor on top

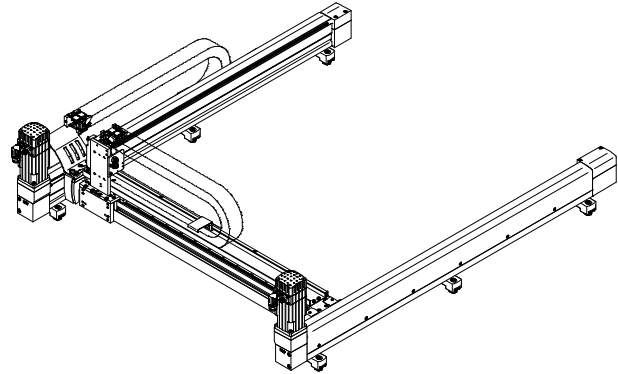

## Mounting positions

Horizontal

- Installation always has energy chain at the top

Vertical

- Only the X-axes may be installed vertically
- Motors must be at the top so that the energy chain can hang freely
- In combination with a control cabinet, the integrated safety switching device with power failure detection (order code S2) must be ordered
- Only in combination with the more powerful motors
  - EXCH-40: order code AB2
  - EXCH-60: order code AB3
- Only use motors with brake
- Braking resistors are essential

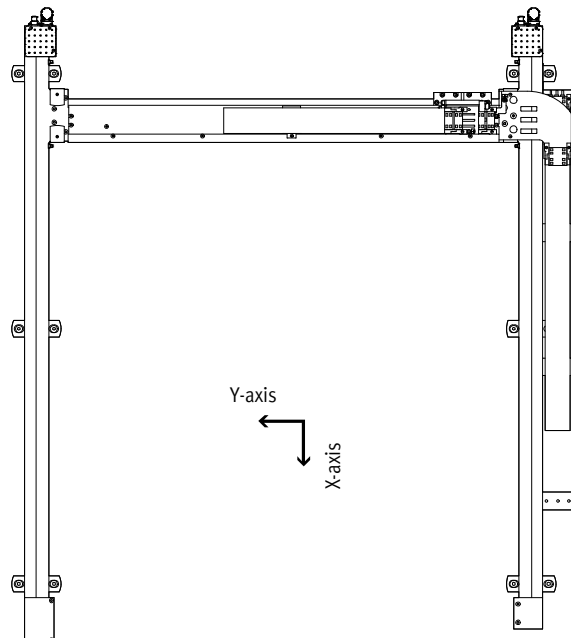
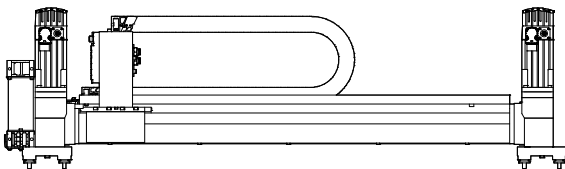

-  - Note

During commissioning, the motor brake must be released for safety purposes.

# Planar surface gantries EXCH

Key features

FESTO

## Selection of attachment components (Z-axis)

Without attachment component

The following are already installed on delivery:

- 1 2 supply ports for e.g. Z-axis
- 2 Multi-pin plug distributor (6-way) for bundling signals:
  - e.g. proximity sensor

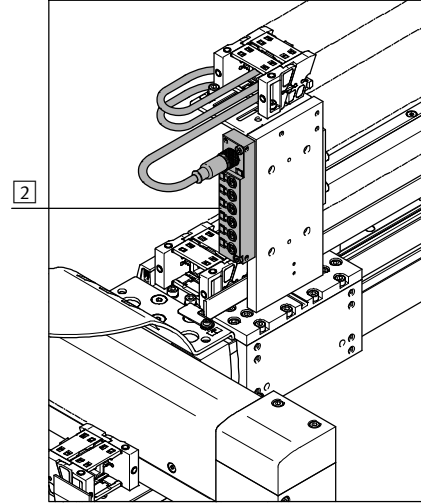
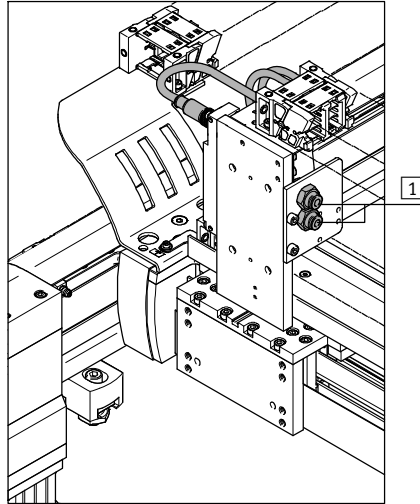

## Attachment component, pneumatic (mini slide DGSL)

The following are already installed on delivery:

- 1 Solenoid valve for controlling the drive
- 2 1 supply port for e.g. gripper
- 3 Multi-pin plug distributor (6-way) for bundling signals:
  - For mini slide DGSL:
    - 2 proximity sensors
    - 1 solenoid valve
    - 3 ports are available
- 4 Proximity sensor for sensing the end positions

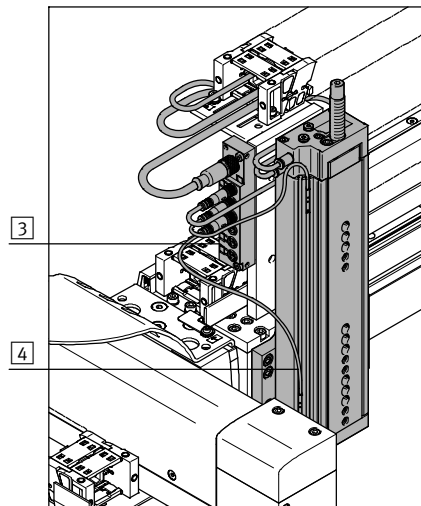
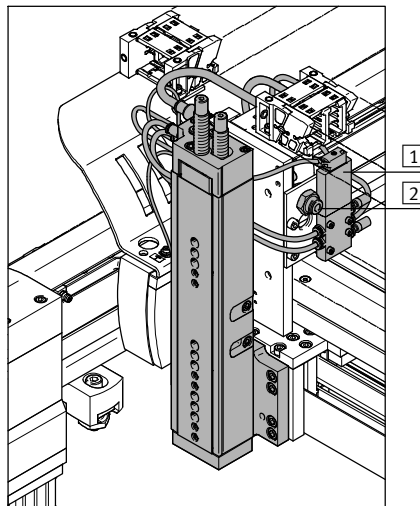

More information → page 18

# Planar surface gantries EXCH

Key features

## Selection of attachment components (Z-axis)

Attachment component, electric (mini slide EGSL)

The following are already installed on delivery:

- 1 2 supply ports for e.g. gripper
- 2 Multi-pin plug distributor (6-way) for bundling signals:
  - e.g. proximity sensor

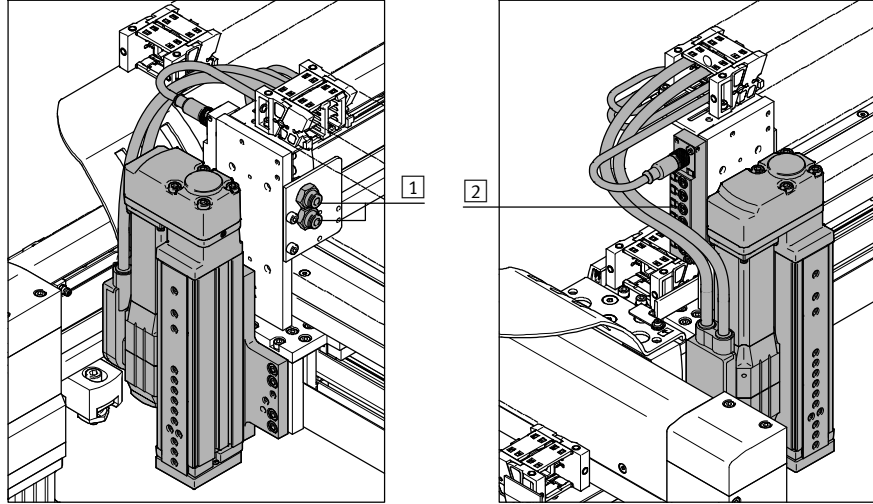

More information → page 18

# Planar surface gantries EXCH

Type codes

EXCH - 40 - 750 - 400 - KF - AB1 - B - L - P2

**Type**

EXCH	Planar surface gantry
------	-----------------------

**Size**

**Stroke of the X-axis [mm]**

**Stroke of the Y-axis [mm]**

**Guide**

KF	Recirculating ball bearing guide
----	----------------------------------

**Motor type**

W	Without motor
AB1	Servo motor, size 70, with brake
AB2	Servo motor, size 100, with brake
AB3	Servo motor, size 140, with brake
AS1	Servo motor, size 70
AS2	Servo motor, size 100
AS3	Servo motor, size 140

**Motor attachment position**

B	Bottom
T	Top

**Energy chain connection side**

L	Left-hand
---	-----------

**Attachment components**

T0	Without attachment components
E1	Electric lifter, 100 mm stroke
E2	Electric lifter, 200 mm stroke
P1	Pneumatic lifter, 50 mm stroke
P2	Pneumatic lifter, 100 mm stroke
P3	Pneumatic lifter, 150 mm stroke
P4	Pneumatic lifter, 200 mm stroke

# Planar surface gantries EXCH

Type codes

		-	5K	-		-	DE
<b>Cable length [m]</b>							
-	Without						
5K	5 m						
10K	10 m						
<b>Mounting kit</b>							
-	With adjusting kit						
P	With mounting kit						
<b>Document language</b>							
DE	German						
EN	English						
ES	Spanish						
FR	French						
IT	Italian						
RU	Russian						
ZH	Chinese						

-  - Note  
 Ordering data → page 32

# Planar surface gantries EXCH

Peripherals overview

FESTO

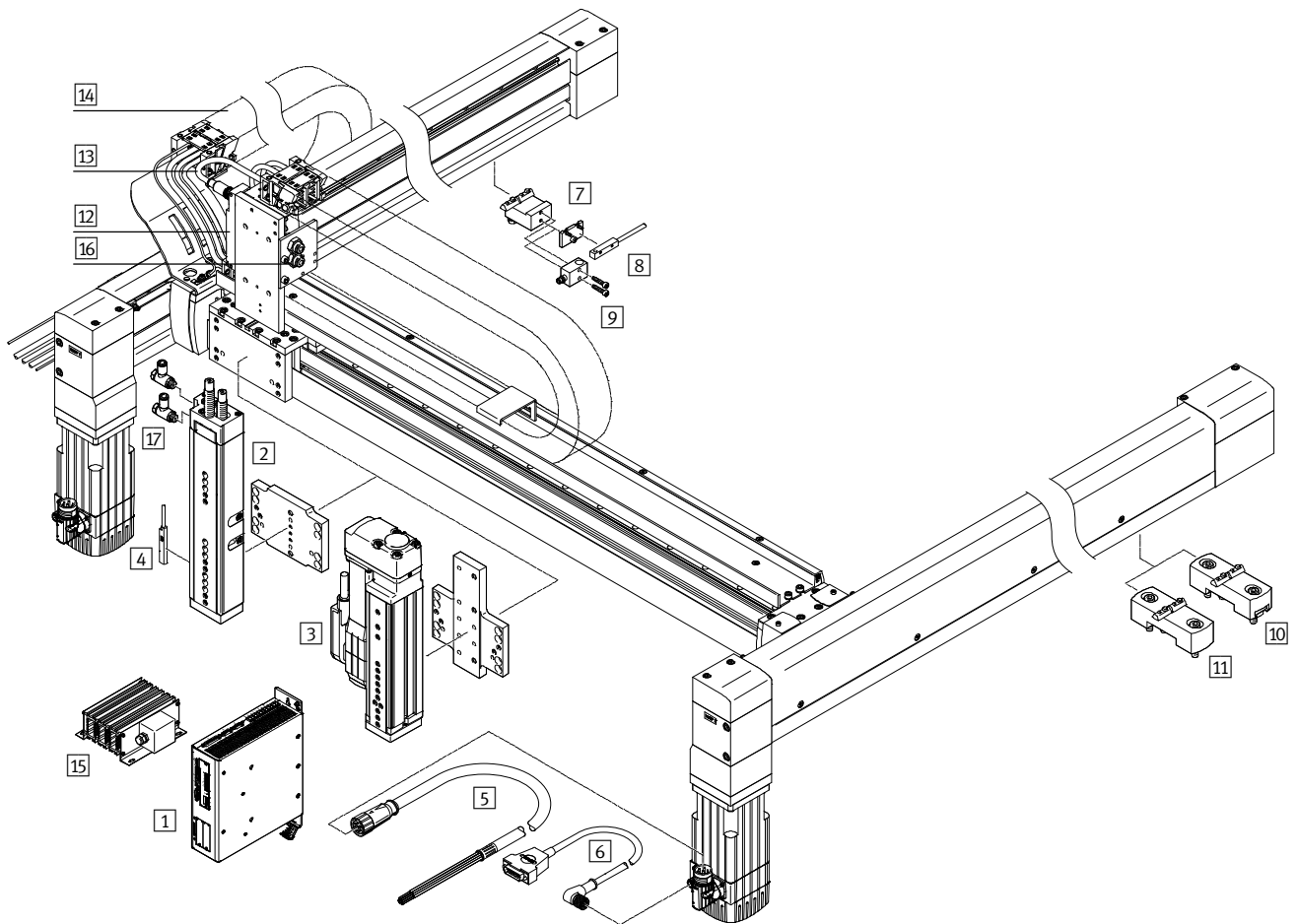

Proximity sensor for sensing the position of the slide on the Y-axis

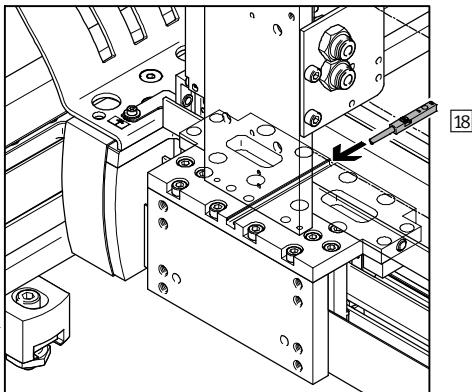



# Planar surface gantries EXCH

Peripherals overview



Attachments and accessories		
Type	Description	→ Page/Internet
1 Motor controller CMMP-AS	<ul style="list-style-type: none"> <li>For controlling the planar surface gantry</li> </ul>	LEERER MERKER
2 Mini slide P1, P2, P3, P4	<ul style="list-style-type: none"> <li>Pneumatic attachment component (mini slide DGSL) for the Z-axis</li> </ul>	32
3 Mini slide E1, E2	<ul style="list-style-type: none"> <li>Electric attachment component (mini slide EGSL) with motor cable NEBM and encoder cable NEBM for the Z-axis</li> </ul>	32
4 Proximity sensor SME-10M	<ul style="list-style-type: none"> <li>For position sensing on the Z-axis</li> <li>Included in the scope of delivery of the planar surface gantry EXCH-...-P...</li> </ul>	35
5 Motor cable NEBM-M23G8	<ul style="list-style-type: none"> <li>Connecting cable between motor and motor controller CMMP-AS</li> <li>Included in the scope of delivery of the planar surface gantry EXCH-...-A...</li> </ul>	36
6 Encoder cable NEBM-M12W8	<ul style="list-style-type: none"> <li>Connecting cable between encoder and motor controller CMMP-AS</li> <li>Included in the scope of delivery of the planar surface gantry EXCH-...-A...</li> </ul>	36
7 Sensor mounting EAPR	<ul style="list-style-type: none"> <li>For mounting the proximity sensors SIES-Q8B, SIES-V3B on the X-axis</li> <li>Not included in the scope of delivery of the planar surface gantry</li> </ul>	22
8 Proximity sensor SIES-Q8B	<ul style="list-style-type: none"> <li>For position sensing on the X-axis</li> <li>Not included in the scope of delivery of the planar surface gantry</li> </ul>	35
9 Proximity sensor SIES-V3B	<ul style="list-style-type: none"> <li>For position sensing on the X-axis</li> <li>Not included in the scope of delivery of the planar surface gantry</li> </ul>	35
10 Adjusting kit EADC-12	<ul style="list-style-type: none"> <li>Height-adjustable mounting kit for the planar surface gantry</li> <li>Included in the scope of delivery of the planar surface gantry. If no adjusting kit is selected in the modular product system, the mounting kit will automatically be delivered</li> </ul>	30
11 Mounting kit EAHM-E12	<ul style="list-style-type: none"> <li>Non-height-adjustable mounting kit for the planar surface gantry</li> </ul>	30
12 Multi-pin plug distributor NEDU	<ul style="list-style-type: none"> <li>For connecting up to 6 inputs/outputs</li> <li>Included in the scope of delivery of the planar surface gantry</li> </ul>	nedu
13 Plug socket with cable SIM	<ul style="list-style-type: none"> <li>Connecting cable between multi-pin plug distributor and controller</li> <li>Included in the scope of delivery of the planar surface gantry</li> </ul>	sim
14 Energy chain	<ul style="list-style-type: none"> <li>For EXCH-40: type IGUS E6.29.040.075.0</li> <li>For EXCH-60: type IGUS E6.35.050.075.0</li> </ul>	-
15 Braking resistor CACR-KL2	<ul style="list-style-type: none"> <li>Essential in the case of a vertical mounting position</li> </ul>	35
16 Plastic tubing PUN-H-6x1	<ul style="list-style-type: none"> <li>Two tubes are connected to the bulkhead fittings and routed in the energy chains on delivery (for pneumatic Z-axis, one tube on the valve and one on the bulkhead fitting)</li> </ul>	pun
17 One-way flow control valve GRLA	<ul style="list-style-type: none"> <li>For speed regulation</li> <li>Included in the scope of delivery of the planar surface gantry EXCH-...-P...</li> </ul>	32
18 Proximity sensor SIES-8M	<ul style="list-style-type: none"> <li>For position sensing on the Y-axis</li> <li>Not included in the scope of delivery of the planar surface gantry</li> </ul>	35
- Motor cable NEBM-T1G8	<ul style="list-style-type: none"> <li>Connecting cable between motor on the Z-axis and motor controller CMMP-AS</li> <li>Included in the scope of delivery of the planar surface gantry EXCH-...-E...</li> </ul>	36
Encoder cable NEBM-T1G8	<ul style="list-style-type: none"> <li>Connecting cable between encoder on the Z-axis and motor controller CMMP-AS</li> <li>Included in the scope of delivery of the planar surface gantry EXCH-...-E...</li> </ul>	36

# Planar surface gantries EXCH

Technical data

Size  
40, 60



General technical data			
Size		40	60
Design		Planar surface gantry	
Guide		Recirculating ball bearing guide	
Stroke of the			
X-axis	[mm]	200 ... 2000	500 ... 2500
Y-axis	[mm]	200 ... 1000	500 ... 1500
Z-axis	[mm]	50, 100, 150, 200	
EXCH-...-E1	[mm]	100	
EXCH-...-E2	[mm]	200	
EXCH-...-P1	[mm]	50	
EXCH-...-P2	[mm]	100	
EXCH-...-P3	[mm]	150	
EXCH-...-P4	[mm]	-	200
Nominal load at max. dynamic response <sup>1)</sup>	[kg]	4	6
Max. torque <sup>2)</sup>	[Nm]	→ page 14	
Max. no-load torque <sup>2)3)</sup>	[Nm]	→ page 15	
Max. acceleration <sup>4)</sup>			
Horizontal	[m/s <sup>2</sup> ]	50	
Vertical	[m/s <sup>2</sup> ]	30	
Max. speed <sup>4)</sup>			
Horizontal	[m/s]	5	
Vertical	[m/s]	4	3
Repetition accuracy	[mm]	±0.1	
Mounting position <sup>5)</sup>		Vertical or horizontal	
Type of mounting		Mounting kit, adjusting kit	

- 1) Nominal load = tool load (attachment component (Z-axis) + gripper, for example) + working load
- 2) These values must also be complied with during installation of third-party motors
- 3) At v=0.2 m/s and 45° travel.
- 4) These data apply only under ideal conditions.  
For a precise configuration please consult a sales engineer from Festo.  
More information → page 15
- 5) Vertical installation only permitted with: motors with brake and braking resistors

## Factoring in software end positions

When selecting the strokes for the X- and Y-axis, the dimension L3 for the software end positions must be taken into account in addition to the working stroke L2. This dimension is freely selectable.

Setting pieces with L3 = 30 mm are included in the scope of delivery of the planar surface gantry.

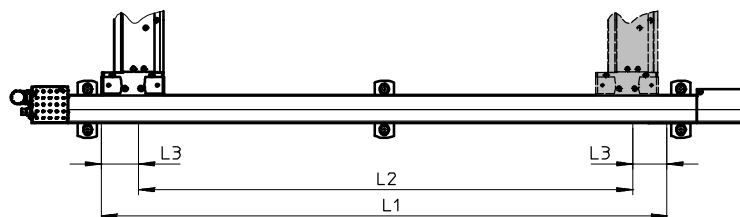

Stroke L1 = working stroke L2 + 2x software end position L3

# Planar surface gantries EXCH

Technical data

Operating and environmental conditions		
Size	40	60
Degree of protection	IP40	
Ambient temperature <sup>1)</sup>	[°C]	+10 ... +50
Storage temperature	[°C]	-10 ... +60
Relative air humidity	[%]	0 ... 90 (non-condensing)
Noise level	[dB(A)]	74
Duty cycle	[%]	100
CE marking (see declaration of conformity)	To EC Machinery Directive	

1) Note operating range of proximity sensors and motors

## Materials

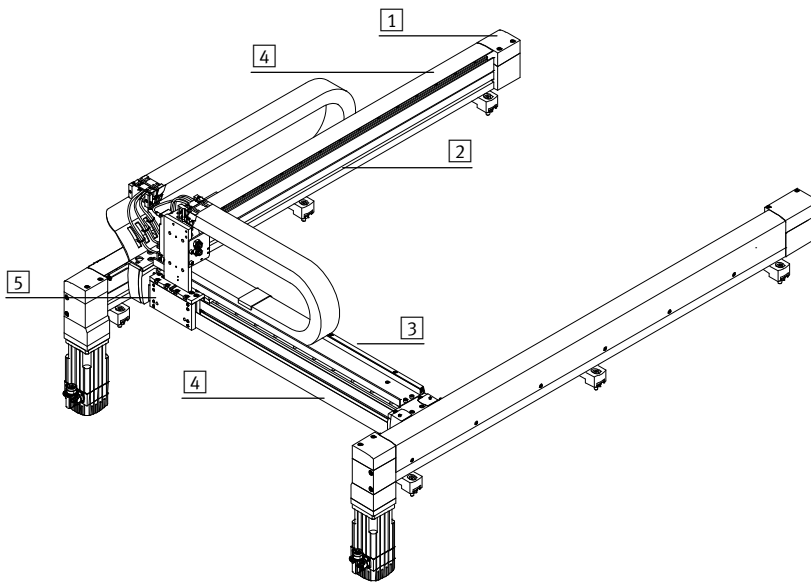

Size	40	60
1 Drive and end caps	Aluminium	
2 Profiles of the X-axis	Aluminium	
3 Profile of the Y-axis	Aluminium	
4 Cover		
X-axis	Aluminium	
Y-axis	Aluminium	
5 Slide	Aluminium	
- Coupling	Aluminium with elastomer ring gear	Clamping hub: aluminium Expanding mandrel hub: stainless steel Collar: elastomer
Guide	Steel	
Drive pinion	Steel	
Ball bearings	Steel	
Toothed belt	PU with steel cord	
Note on materials	RoHS-compliant	
	Contains PWIS (paint-wetting impairment substances)	

# Planar surface gantries EXCH

Technical data

Weight [kg]		
Size	40	60
Product weight with 0 mm stroke (without nominal load, motors, axial kits, mounting kits)		
X-axis and Y-axis	16.6	37.9
Y-axis (without slide)	6.0	11.5
Additional weight per 100 mm stroke		
X-axis	1.69	2.21
Y-axis	0.81	0.99
Axial kit <sup>1)</sup>		
For EMMS-AS-70/-100	0.66	1.33
For EMMS-AS-100/-140	1.02	2.06
Motor <sup>1)</sup>		
Without brake		
EXCH-...-AS1	2.7	–
EXCH-...-AS2	4.8	6.9
EXCH-...-AS3	–	9.6
With brake		
EXCH-...-AB1	2.9	–
EXCH-...-AB2	5.3	7.5
EXCH-...-AB3	–	10.4
Attachment component (Z-axis)		
Electrical		
EXCH-...-E1	3.4	5.3
EXCH-...-E2	4.0	6.2
Pneumatic		
EXCH-...-P1	1.8	2.7
EXCH-...-P2	2.4	3.6
EXCH-...-P3	2.7	4.3
EXCH-...-P4	–	5.0
Mounting kit for X-axis		
Adjusting kit <sup>1)</sup>	0.78	0.89
Mounting kit <sup>1)</sup>	0.33	0.37

1) Weight per component

# Planar surface gantries EXCH

Technical data

## Acceleration $a$ as a function of the nominal load and stroke of the Y-axis

### EXCH-40

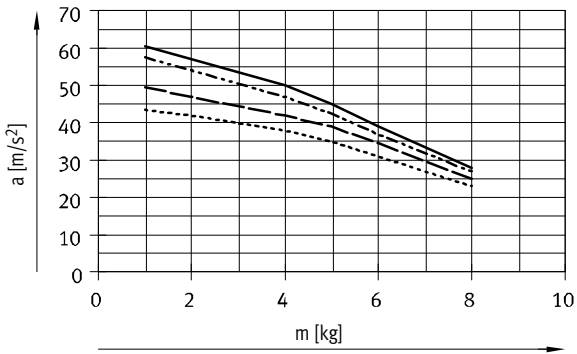

- Stroke, Y-axis = 400 mm
- - - Stroke, Y-axis = 500 mm
- · - Stroke, Y-axis = 750 mm
- · · Stroke, Y-axis = 1000 mm

### EXCH-60

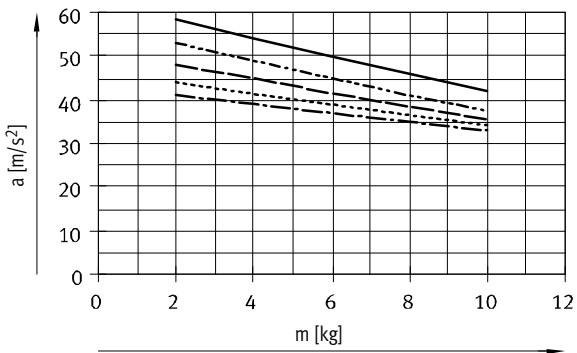

- Stroke, Y-axis = 500 mm
- - - Stroke, Y-axis = 750 mm
- · - Stroke, Y-axis = 1000 mm
- · · Stroke, Y-axis = 1250 mm
- - - Stroke, Y-axis = 1500 mm

# Planar surface gantries EXCH

Technical data

## Torque M as a function of rotational speed n

Typical motor characteristic curve with nominal torque. The rms value of the torque for the respective positioning cycle must remain below the nominal torque. The torque may briefly exceed the nominal torque.

### EXCH-40

In conjunction with:  
EMMS-AS-70-M-LS-RM, EMMS-AS-70-M-LS-RMB  
and CMMP-AS-C5-3A

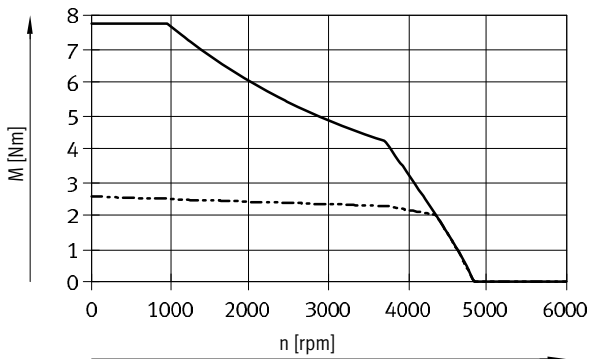

— Max. torque  
- - - Nominal torque

In conjunction with:  
EMMS-AS-100-S-HS-RM, EMMS-AS-100-S-HS-RMB  
and CMMP-AS-C5-11A

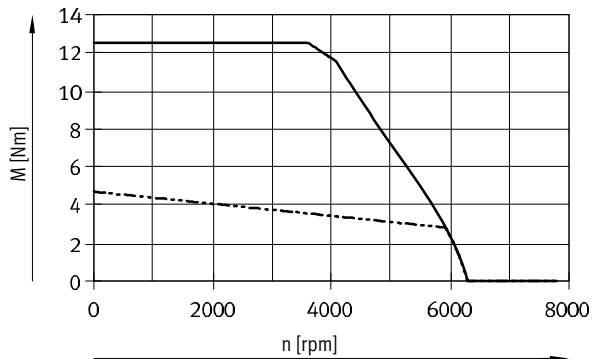

— Max. torque  
- - - Nominal torque

### EXCH-60

In conjunction with:  
EMMS-AS-100-M-HS-RM, EMMS-AS-100-M-HS-RMB  
and CMMP-AS-C5-11A

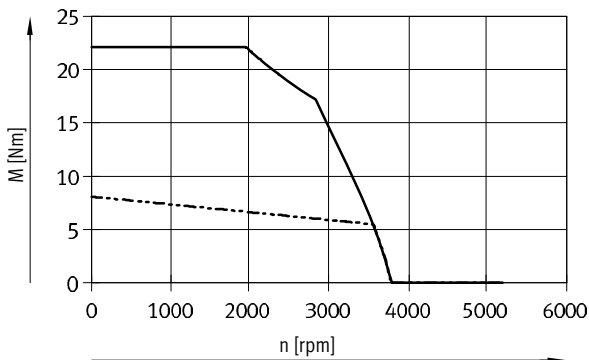

— Max. torque  
- - - Nominal torque

In conjunction with:  
EMMS-AS-140-S-HV-RM, EMMS-AS-140-S-HV-RMB  
and CMMP-AS-C5-11A

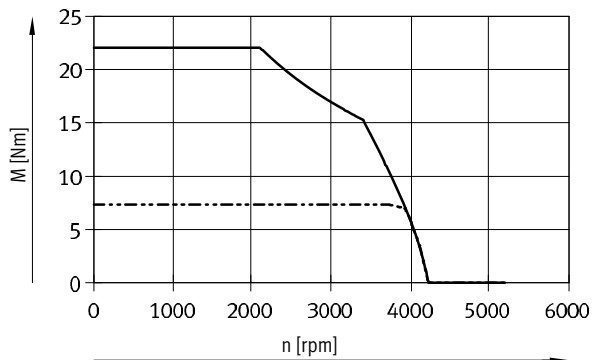

— Max. torque  
- - - Nominal torque

# Planar surface gantries EXCH

Technical data

## No-load torque M as a function of speed n

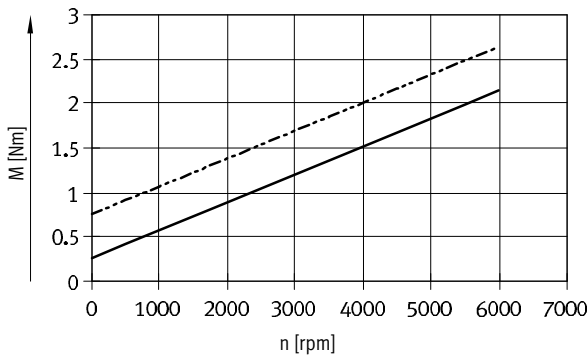

— EXCH-40  
 - - - EXCH-60

## Characteristic load values

The following information applies for a horizontal mounting position. For vertical installation positions, please get in touch with your local contact at Festo.

The centre of gravity of the slide is at the height of the slide in the Z-direction and in the centre of the slide in the X-/Y-directions.

The system is subject to the greatest load in the case of 45° travel. The following data apply in this case:

## Formula for calculating the required torque M and the required nominal rotary speed n

### For EXCH-40:

$$M_{45^\circ} = a \times (9.79 \times m_L + 4.89 \times m_{Ay} + 10.21 \times J_m + 19.58) \times 10^{-3} + M_R$$

$$n_{45^\circ} = 975 \times v$$

### For EXCH-60:

$$M_{45^\circ} = a \times (14.07 \times m_L + 7.03 \times m_{Ay} + 7.11 \times J_m + 49.24) \times 10^{-3} + M_R$$

$$n_{45^\circ} = 679 \times v$$

- a = acceleration [m/s<sup>2</sup>]
- v = speed [m/s]
- m<sub>Ay</sub> = product weight at the Y-axis [kg]  
→ page 12
- m<sub>L</sub> = attachment component (Z-axis) [kg] with payload
- J<sub>m</sub> = moment of inertia of motor [kgcm<sup>2</sup>]  
→ table below
- M<sub>R</sub> = no-load torque [Nm]  
→ page 15
- n<sub>45°</sub> = nominal rotary speed for 45° travel [rpm]

## Allocation of planar surface gantry to servo motor for X-/Y-axis

Planar surface gantry	Motor	Moment of inertia of motor [kgcm <sup>2</sup> ]
EXCH-40-...-AB1	EMMS-AS-70-M-LS-RMB	0.68
EXCH-40-...-AS1	EMMS-AS-70-M-LS-RM	0.611
EXCH-40-...-AB2 <sup>1)</sup>	EMMS-AS-100-S-HS-RMB	3.085
EXCH-40-...-AS2	EMMS-AS-100-S-HS-RM	2.529
EXCH-60-...-AB2	EMMS-AS-100-M-HS-RMB	5.285
EXCH-60-...-AS2	EMMS-AS-100-M-HS-RM	4.729
EXCH-60-...-AB3 <sup>1)</sup>	EMMS-AS-140-S-HV-RMB	9.271
EXCH-60-...-AS3	EMMS-AS-140-S-HV-RM	8.189

1) Essential when the planar surface gantry is mounted vertically.

# Planar surface gantries EXCH

Technical data

## Sample calculation

### Given:

Planar surface gantry  
EXCH-40-1000-500-KF-AS2-B-L-E1-...  
with attached motor  
EMMS-AS-100-S-HS-RMB

$$a_{\max} = 25 \text{ m/s}^2$$

$$v_{\max} = 2 \text{ m/s}$$

Payload = 0.5 kg

Attachment component Z-axis: EGSL-BS-45-100-3P

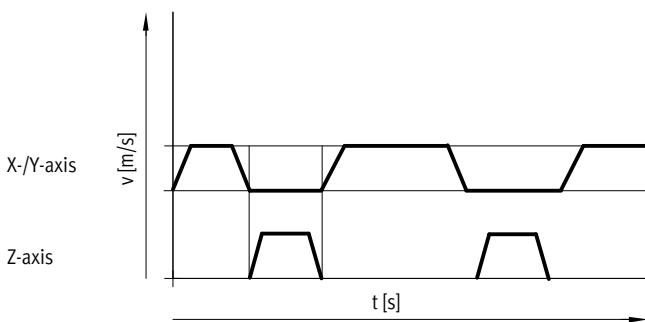

### Calculation:

#### 1. What is the max. acceleration permitted by the mechanical system?

Moving mass  $m_l$  at the Y-axis:

Z-axis 3.40 kg  
Payload 0.50 kg  
= 3.90 kg

Stroke of the Y-axis:  
500 mm

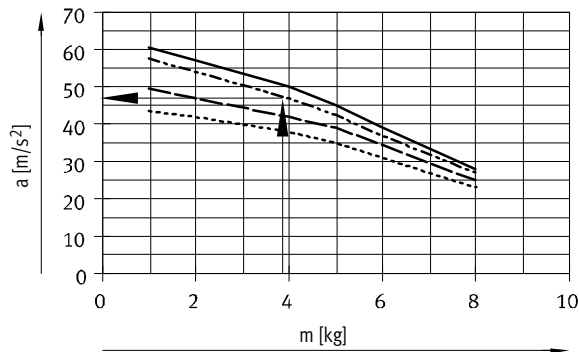

- Stroke, Y-axis = 400 mm
- - - Stroke, Y-axis = 500 mm
- · - Stroke, Y-axis = 750 mm
- · · Stroke, Y-axis = 1000 mm

### Result:

In the case of a moving mass  $m_l$  of 3.9 kg, the maximum permissible acceleration is  $46 \text{ m/s}^2$ .

The requested acceleration of  $25 \text{ m/s}^2$  is thus permissible.



# Planar surface gantries EXCH

Technical data

## Sample calculation

### 2. Is the attached motor sufficient for this load?

**Given:**

$$a_{\max} = 25 \text{ m/s}^2$$

$$v_{\max} = 2 \text{ m/s}$$

$$m_{Ay} = 10.05 \text{ kg}$$

$$m_L = 3.90 \text{ kg}$$

$$J_m = 3.085 \text{ kgcm}^2$$

$$M_{45^\circ} = a \times (9.79 \times m_L + 4.89 \times m_{Ay} + 10.21 \times J_m + 19.58) \times 10^{-3} + M_R$$

$$n_{45^\circ} = 975 \times v$$

a = acceleration [m/s<sup>2</sup>]

v = speed [m/s]

m<sub>Ay</sub> = product weight at the Y-axis [kg]

→ page 12

m<sub>L</sub> = attachment component (Z-axis) [kg]  
with payload

J<sub>m</sub> = moment of inertia of motor [kgcm<sup>2</sup>]

→ page 15

M<sub>R</sub> = no-load torque [Nm]

→ page 15

n<sub>45°</sub> = nominal rotary speed for 45° travel [rpm]



Note

These requirements for the dynamic response apply to 45° travel.  
For travel only in the X- or Y-direction, the dynamic values may be higher.

### Determination of M<sub>R</sub>:

$$n_{45^\circ} = 975 \times 2 \text{ m/s} = 1950 \text{ 1/min}$$

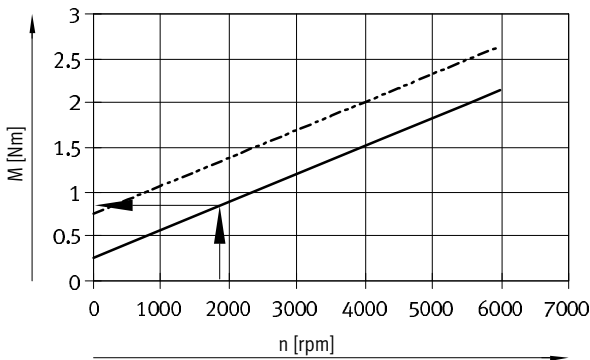

No-load torque:

— EXCH-40

- - - EXCH-60

$$M_R = 0.9 \text{ Nm}$$

$$M_{45^\circ} = a \times (9.79 \times m_L + 4.89 \times m_{Ay} + 10.21 \times J_m + 19.58) \times 10^{-3} + M_R$$

$$M_{45^\circ} = 25 \frac{\text{m}}{\text{s}^2} \times (9.79 \times 3.90 \text{ kg} + 4.89 \times 10.05 \text{ kg} + 10.21 \times 3.085 \text{ kgcm}^2 + 19.58) \times 10^{-3} + 0.9 \text{ Nm} = 4.36 \text{ Nm}$$

### Result:

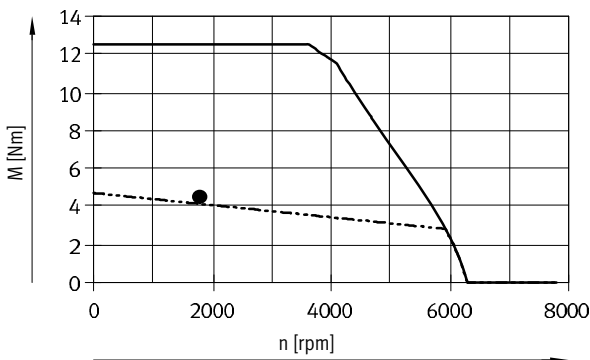

— Max. torque

- - - Nominal torque

The value for the torque is above the nominal torque and below the maximum torque.

This torque is only required in the acceleration phases.

The design is fine, depending on the travel profile.

# Planar surface gantries EXCH

Technical data

## Selection of attachment components

The following variants for the Z-axis can optionally be ordered using the modular product system → page 32:

- Without attachment component
- With pneumatic attachment component (mini slide DGSL)
- With electric attachment component (mini slide EGSL)

The drives are delivered fully connected. Cables and tubing are routed as far as the output of the energy chain (X-axis).

## EXCH-...-TO... (without attachment component)

The following are preinstalled:

- 2 supply ports for e.g. Z-axis
- Multi-pin plug distributor for bundling signals:
  - e.g. proximity sensor

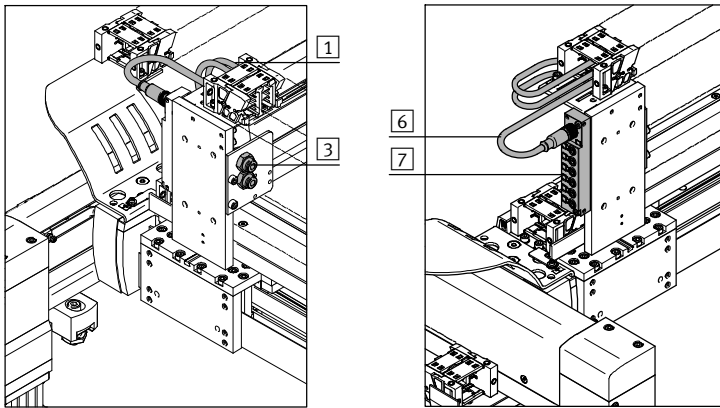

Components affected	Number of components
1 Tubing	2
3 Bulkhead fitting	2
6 Plug socket with cable	1
7 Multi-pin plug distributor (6-way)	1
– Earthing cable	2

## EXCH- ... -P... (pneumatic attachment component)

The following are preinstalled:

- Solenoid valve for controlling the drive
- 1 supply port for e.g. gripper
- Proximity sensor for end position sensing
- Multi-pin plug distributor for bundling signals:
  - For mini slide DGSL:
    - 2 proximity sensors
    - 1 solenoid valve
  - 3 ports are available

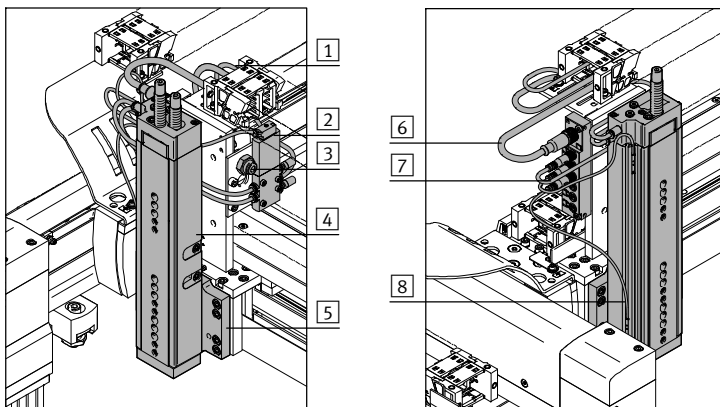

Components affected	Number of components
1 Tubing	2
2 Solenoid valve	1
3 Bulkhead fitting	1
4 Mini slide DGSL-...-Y3A <sup>1)</sup>	1
5 Adapter plate	1
6 Plug socket with cable	1
7 Multi-pin plug distributor (6-way)	1
8 Proximity sensor	2
– Earthing cable	2

1) For EXCH-40, the mini slide DGSL-16 is used with progressive shock absorbers. For EXCH-60, the mini slide DGSL-20 is used with progressive shock absorbers. More information → Internet: dgs1

# Planar surface gantries EXCH

Technical data

## Selection of attachment components

EXCH-...-E... (electrical attachment component)

The following are preinstalled:

- 2 supply ports for e.g. gripper
- Multi-pin plug distributor for bundling signals:
  - e.g. proximity sensor

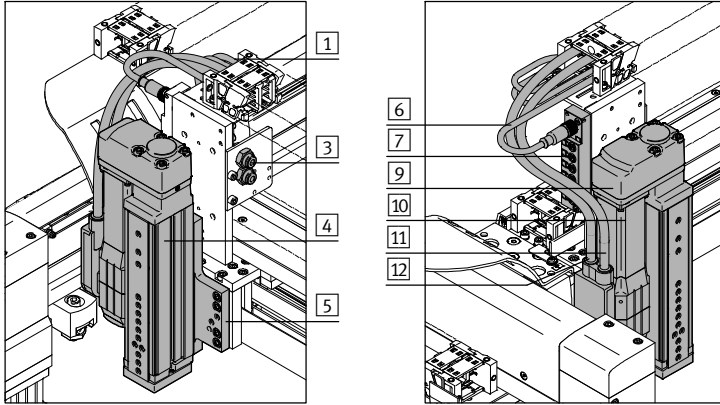

Components affected	Number of components
1 Tubing	2
3 Bulkhead fitting	2
4 Mini slide EGSL <sup>1)</sup>	1
5 Adapter plate	1
6 Plug socket with cable	1
7 Multi-pin plug distributor (6-way)	1
9 Parallel kit	1
10 Motor	1
11 Motor cable	1
12 Encoder cable	1
- Earthing cable	2

1) For EXCH-40, the mini slide EGSL-45 is used with a lead of 10 mm.  
 For EXCH-60, the mini slide EGSL-55 is used with a lead of 12.7 mm.  
 More information → Internet: egsl

## Mounting position of the Z-axis

Owing to manufacturing tolerances and the backlash in the guides, the angle between the X- and Z-axes may not be exactly 90° in certain circumstances.

Max. deviation:

EXCH-40:  $\alpha = \pm 1.1^\circ$

EXCH-60:  $\alpha = \pm 2.1^\circ$

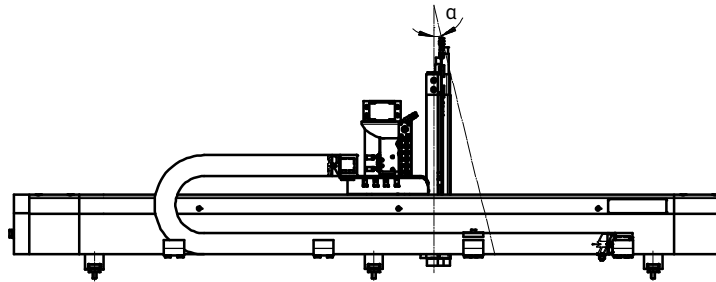

## Selection of cable lengths

2 cable lengths (5 m or 10 m) can be selected using the modular product system → page 32. This specification relates to the output of the energy chain at the X-axis (dimension L) and describes the minimum length by which the cables and tubing protrude. The selected length applies to the following components:

- Tubing
- Plug sockets with cable
- Motor cables
- Encoder cables
- Earthing cables

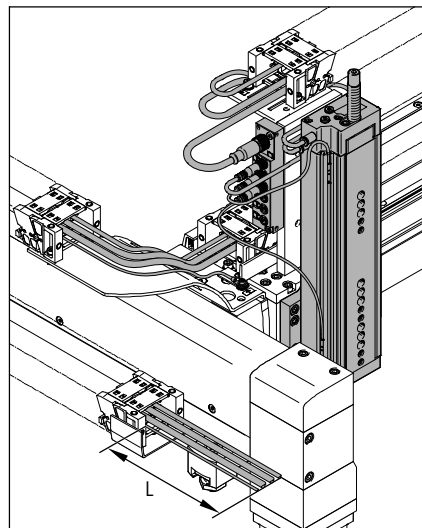

# Planar surface gantries EXCH

Technical data

## Number of profile mountings

Irrespective of the mounting position, a different number of profile mountings need to be used depending on

the stroke of the X-axis.  
The item is delivered with the required number attached.

Stroke of the X-axis [mm]	Number of profile mountings per axis	
	EXCH-40	EXCH-60
200 ... 499	2	-
500 ... 899	2	-
900 ... 1799	3	-
1800 ... 2000	4	-
2000 ... 2500	-	4

## Spacings of the profile mountings

The profile mountings must be uniformly spaced from one another by the distance l.

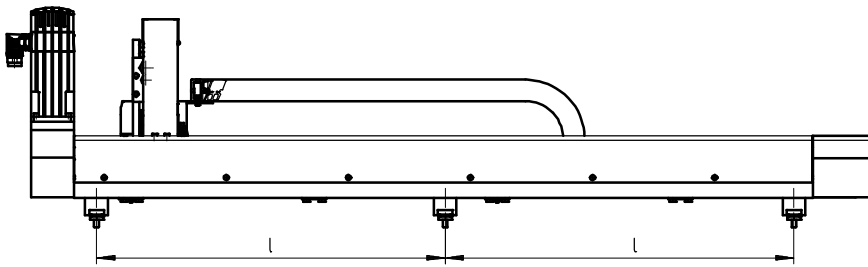

For EXCH-40

For EXCH-60

$$\text{Distance } l = \frac{\text{stroke} + 141}{n - 1}$$

$$\text{Distance } l = \frac{\text{stroke} + 328}{n - 1}$$

n = number of profile mountings per axis

# Planar surface gantries EXCH

Technical data

## Pin allocations

Motors on the X-/Y-axis

Motor (M23, pins)

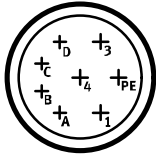

PIN	Function	Colour
1	U Phase U	BK (1)
PE	PE Protective earth	GNYE
3	W Phase W	BK (3)
4	V Phase V	BK (2)
A	M <sub>T+</sub> Temperature sensor	WH
B	M <sub>T-</sub> Temperature sensor	BN
C	BR+ Brake	GN
D	BR- Brake	YE

Encoder (M12, pins)

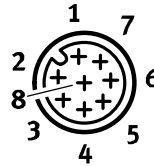

PIN	Function
1	-SENS
2	+SENS
3	DATA
4	DATA/
5	0 V
6	CLOCK/
7	CLOCK
8	UP

Motor on the Z-axis

Motor

Black plug connector

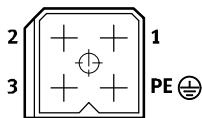

PIN	Function	Colour
1	Phase V	BK (2)
2	Phase W	BK (3)
3	Phase U	BK (1)
PE	PE Protective earth	GNYE

Temperature sensor and brake

Blue plug connector

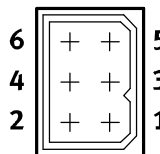

PIN	Function	Colour
1	M <sub>T+</sub> Temperature sensor	WH
2	M <sub>T-</sub> Temperature sensor	BN
3	BR+ Brake	GN
4	BR- Brake	YE
5	n.c.	-
6	n.c.	-

Encoder

Red plug connector

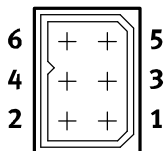

PIN	Function
1	DATA
2	DATA/
3	0 V
4	UP
5	CLOCK/
6	CLOCK

Encoder

Yellow plug connector

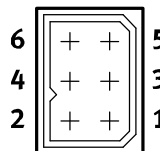

PIN	Function
1	-SENS
2	+SENS
3	n.c.
4	n.c.
5	n.c.
6	n.c.

# Planar surface gantries EXCH

Technical data

FESTO

## Dimensions

Download CAD data → [www.festo.com](http://www.festo.com)

EXCH-40-...-T – Motor attachment position on top

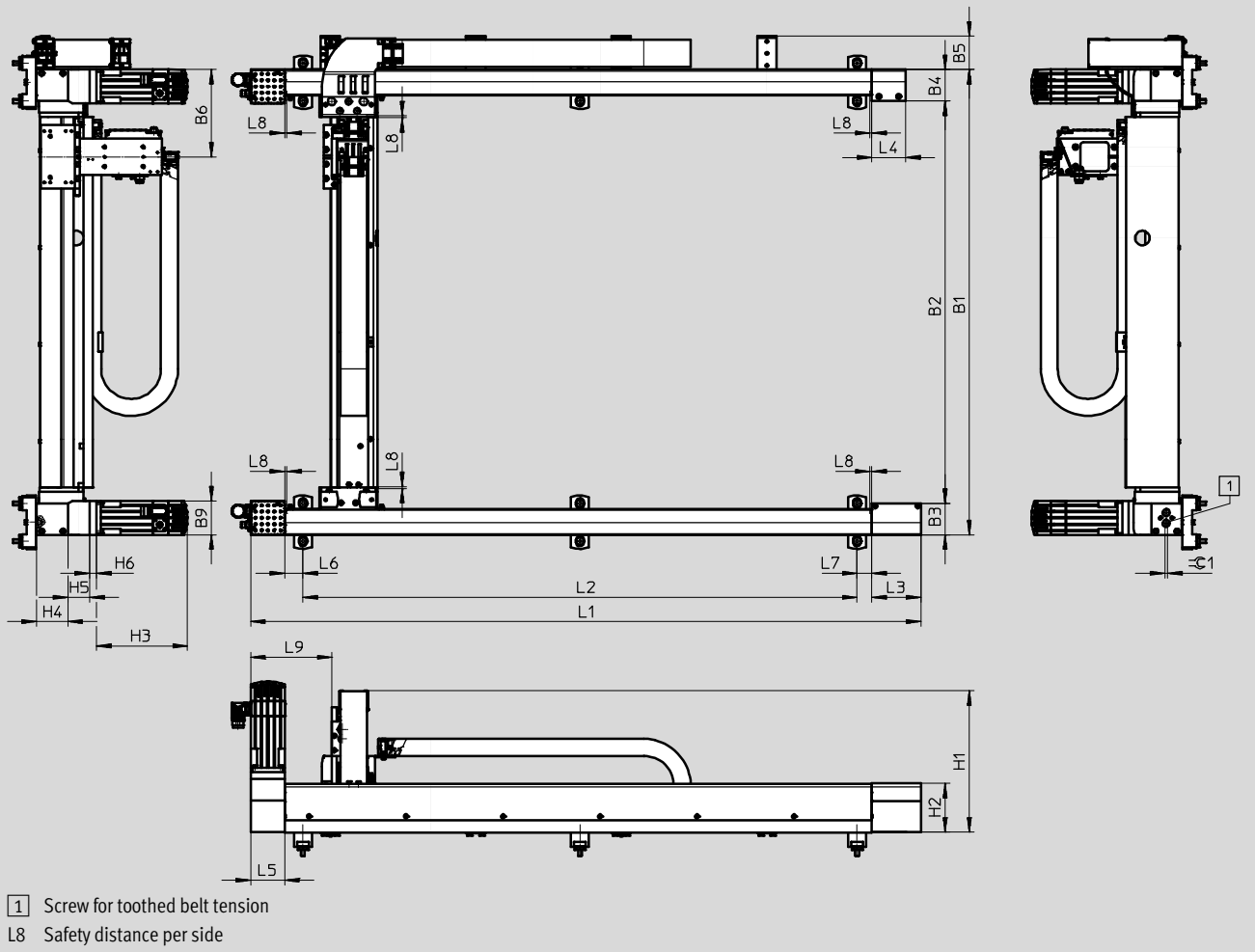

EXCH-40-...-B – Motor attachment position underneath

EXCH-40-... – Motor interface

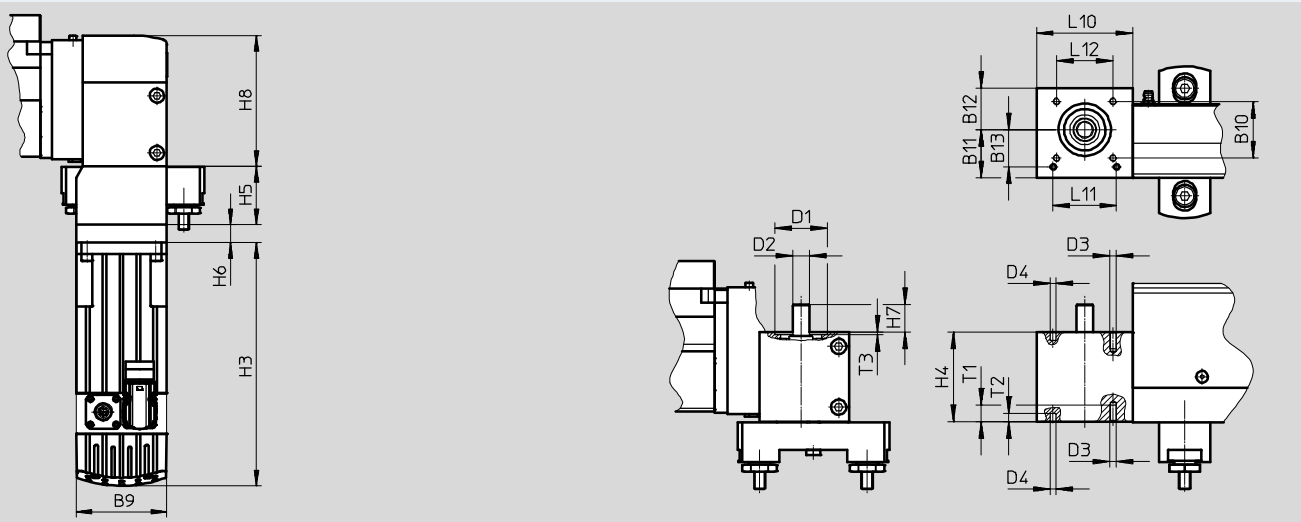

# Planar surface gantries EXCH

Technical data

## Dimensions

Download CAD data → [www.festo.com](http://www.festo.com)

EXCH-40-... – Slide

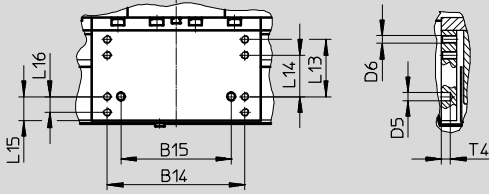

Type	B3	B4	B5	B6	B9	B10	B11	B12	B13	B14
									±0.05	±0.1
With EMMS-AS-70	65	65	69	179.9	70	41	35	30	27	106
With EMMS-AS-100	65	65	69	179.9	100.5					

Type	B15	D1	D2	D3	D4	D5	D6	H1	H2	H3
	±0.03	∅ H7	∅ H6		∅ H7	∅ H7				
With EMMS-AS-70	85	38	12	M5	4	6	M6	Approx. 293	100.8	187.3
With EMMS-AS-100										192.3

Type	H4	H5	H6	H7	H8	L3	L4	L5	L6	L7	L8	L9
With EMMS-AS-70	65	44.9	13.8	20	100.3	101	70	70	37.5	30.5	4	167.2
With EMMS-AS-100		57	20.1									

Type	L10	L11	L12	L13	L14	L15	L16	T1	T2	T3	T4	≈C1
		±0.03		±0.1	±0.1		±0.1					
With EMMS-AS-70	70	46	41	44	32	18.5	12	12	6	1.9	7	6
With EMMS-AS-100												

## Stroke-dependent dimensions

Stroke of the X-axis	L1	L2	Stroke of the Y-axis	B1	B2
500	882	641	400	760	630
750	1132	891	500	860	730
1000	1382	1141	750	1100	980
1500	1882	1641	1000	1360	1230
200 ... 2000	382+stroke	→ page 20	200 ... 1000	360+stroke	230+stroke

## Note

A different number of profile mountings is required depending on the stroke of the X-axis. The spacing between the profile mountings must always be the same (→ page 20).

The tension of the toothed belt must be adjusted in preparation for commissioning. The tools required for this (e.g. frequency meter) are not included in the scope of delivery.

# Planar surface gantries EXCH

Technical data

FESTO

## Dimensions

Download CAD data → [www.festo.com](http://www.festo.com)

EXCH-60-...-T – Motor attachment position on top

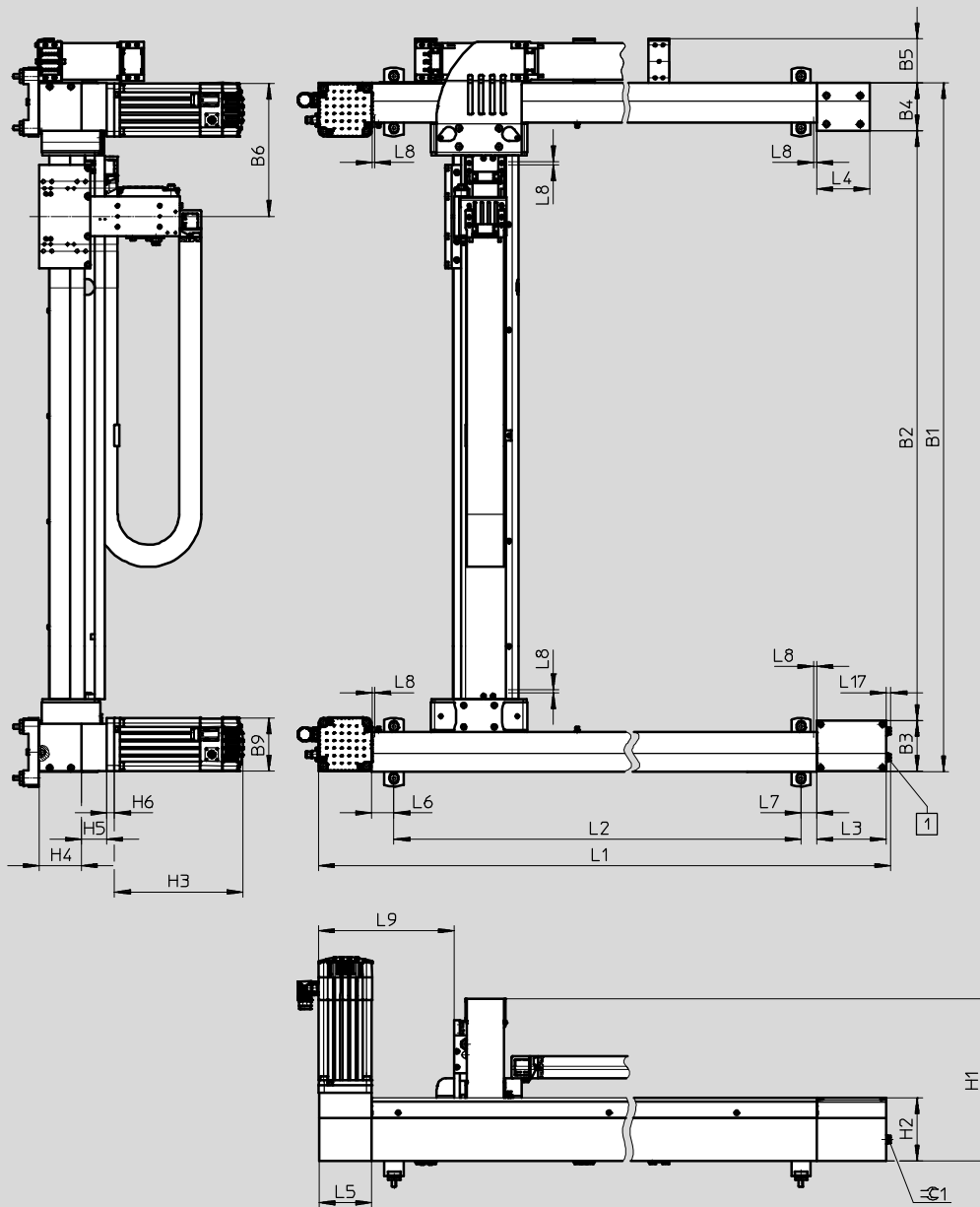

- 1 Screw for toothed belt tension
- L8 Safety distance per side



# Planar surface gantries EXCH

Technical data

Type	B3	B4	B5	B6	B9	H1
With EMMS-AS-100	96.6	91	83.5	253.3	100.5	Approx. 310
With EMMS-AS-140					140.5	

Type	H2	H3	H4	H5	H6	L3	L4
With EMMS-AS-100	120.1	243.3	80.6	48	14.5	131.2	100
With EMMS-AS-140		209			24.5		

Type	L5	L6	L7	L8	L9	L17	≈C1
With EMMS-AS-100	100	42.5	30.5	6	257	8.9	13
With EMMS-AS-140							

Stroke-dependent dimensions						
Stroke of the X-axis	L1	L2	Stroke of the Y-axis	B1	B2	
750	1393	1078	500	1007	819	
1000	1643	1328	750	1257	1069	
1500	2143	1828	1000	1507	1319	
2000	2643	2328	1250	1757	1569	
500 ... 2500	643 + stroke	→ page 20	1500	2007	1819	
			500 ... 1500	507 + stroke	319 + stroke	

 Note

A different number of profile mountings is required depending on the stroke of the X-axis. The spacing between the profile mountings must always be the same (→ page 20).

The tension of the toothed belt must be adjusted in preparation for commissioning. The tools required for this (e.g. frequency meter) are not included in the scope of delivery.

# Planar surface gantries EXCH

Technical data



Dimensions Download CAD data → [www.festo.com](http://www.festo.com)

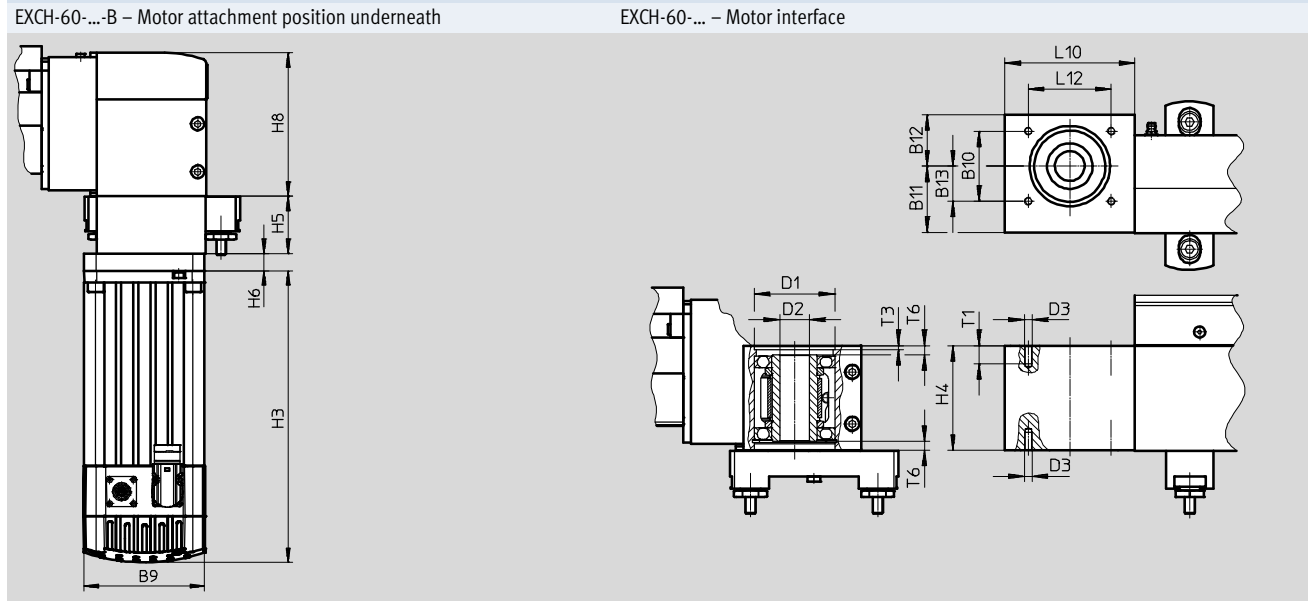

EXCH-60-... – Slide

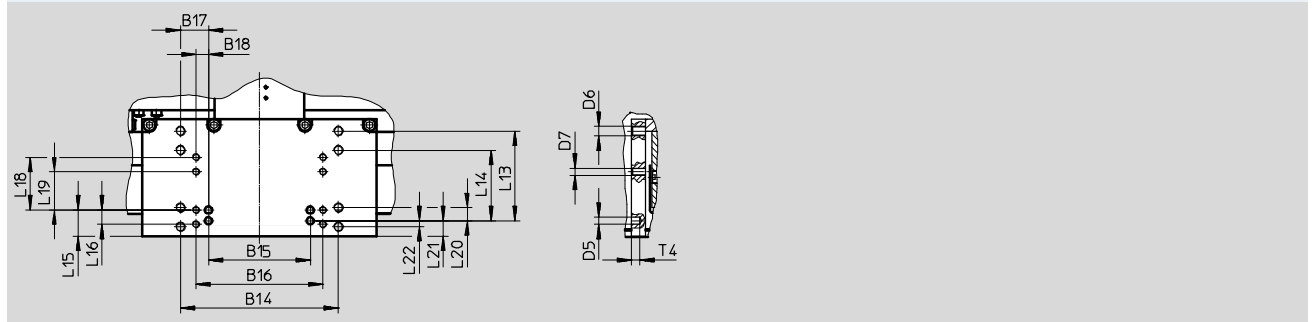

Type	B9	B10	B11	B12	B13	B14	B15	B16	B17
		±0.1			±0.05	±0.1	±0.03	±0.1	±0.1
With EMMS-AS-100	100.5	54	51	39.5	27	132	85	106	23.5
With EMMS-AS-140	140.5								

Type	B18	D1	D2	D3	D5	D6	D7	H3	H4	H5
	±0.1	∅ H7	∅ H7		∅ H7					
With EMMS-AS-100	10.5	62	23	M6	6	M8	M6	243.3	80.6	48
With EMMS-AS-140								209		

Type	H6	H8	L10	L12	L13	L14	L15	L16	L18
				±0.1	±0.1	±0.1		±0.1	±0.1
With EMMS-AS-100	14.5	119.6	100	64	75	59	22	12	44
With EMMS-AS-140	24.5								

Type	L19	L20	L21	L22	T1	T3	T4	T6
	±0.1	±0.1						
With EMMS-AS-100	32	11	13	5	14	3.1	7	6.9
With EMMS-AS-140								

# Planar surface gantries EXCH

Technical data



## Dimensions

Download CAD data → [www.festo.com](http://www.festo.com)

EXCH-40-...-P...

EXCH-40-...-E...

With pneumatic attachment component (mini slide DGSL)

With electric attachment component (mini slide EGSL)

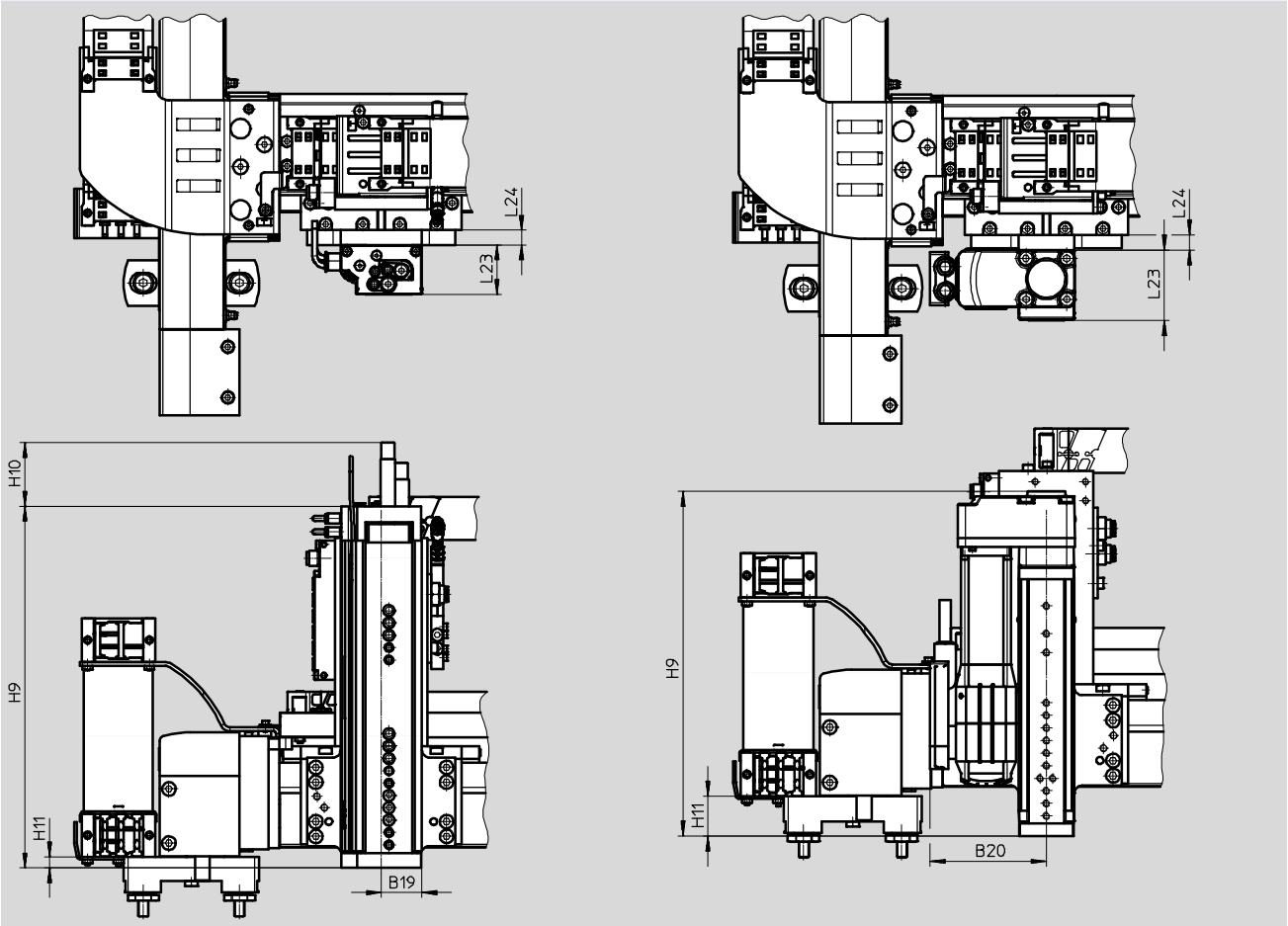

Type	B19	B20	H9	H10 Max.	H11	L23	L24
With pneumatic attachment component (mini slide DGSL)							
EXCH-40-...-P1	33	-	164.6	51.9	9.1	40±0.08	12
EXCH-40-...-P2			243.6				
EXCH-40-...-P3			293.6				
With electric attachment component (mini slide EGSL)							
EXCH-40-...-E1	-	92.3	274	-	31.5	56	12
EXCH-40-...-E2			374				

# Planar surface gantries EXCH

Technical data

## Dimensions

Download CAD data → [www.festo.com](http://www.festo.com)

EXCH-60-...-P...

With pneumatic attachment component (mini slide DGSL)

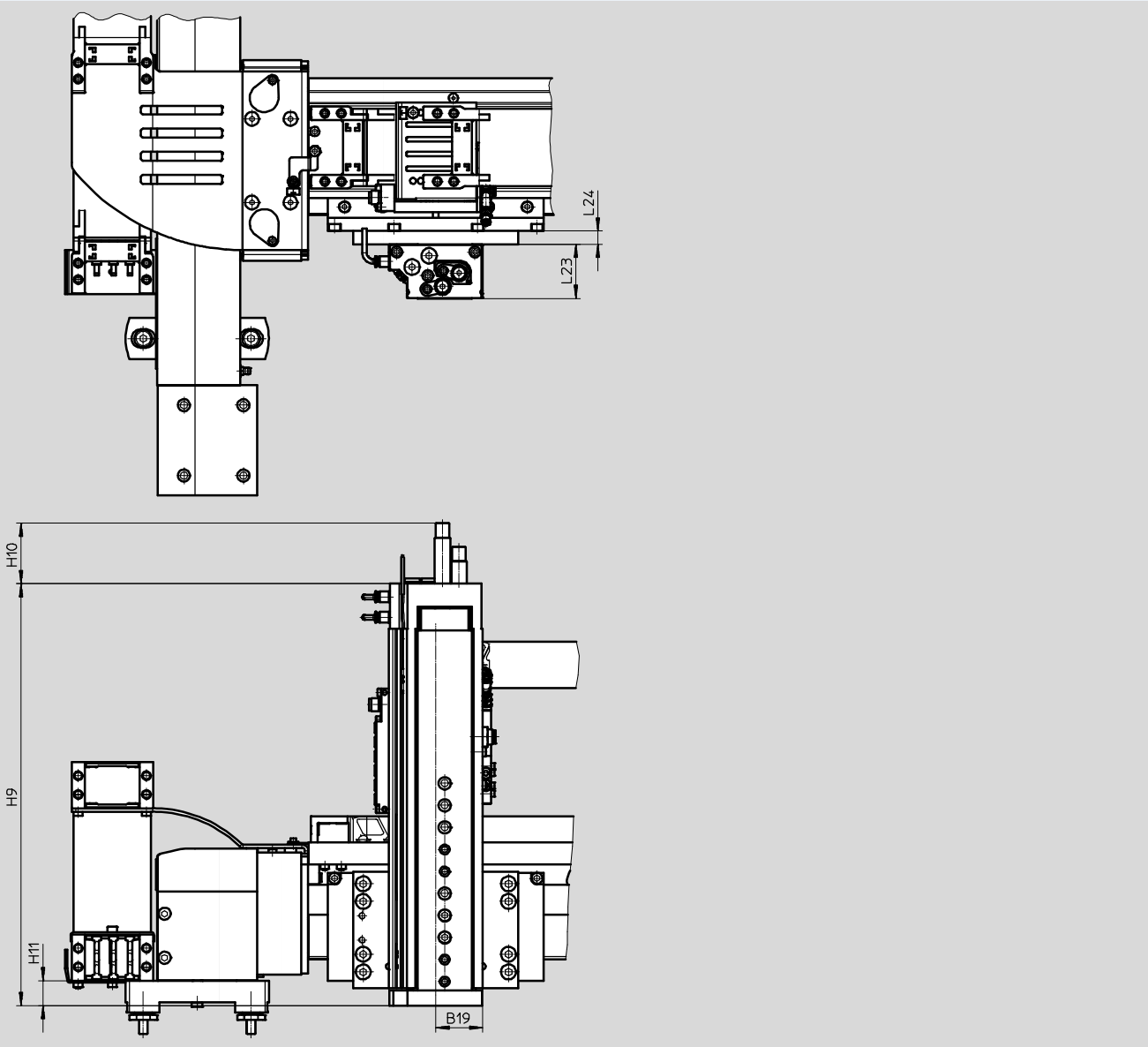

Type	B19	H9	H10 Max.	H11	L23 ±0.08	L24
EXCH-60-...-P1	42.5	183.2	55.5	22.7	49	12
EXCH-60-...-P2		270.2				
EXCH-60-...-P3		333.2				
EXCH-60-...-P4		383.2				

# Planar surface gantries EXCH

Technical data

## Dimensions

Download CAD data → [www.festo.com](http://www.festo.com)

EXCH-60-...-E...

With electric attachment component (mini slide EGSL)

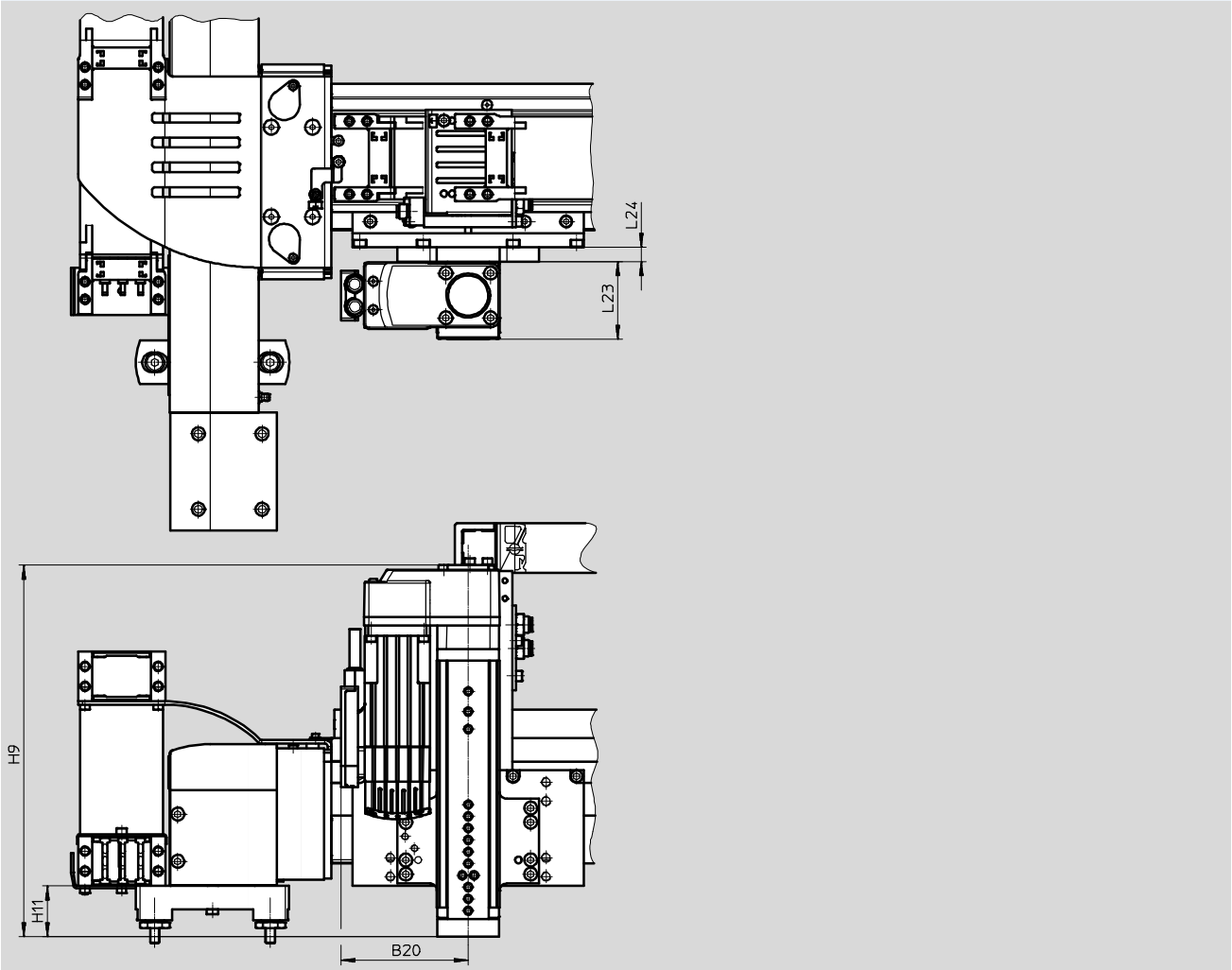

Type	B20	H9	H11	L23	L24
EXCH-60-...-E1	108	315	43	66	12
EXCH-60-...-E2		415			

# Planar surface gantries EXCH

Technical data

FESTO

## Dimensions

Download CAD data → [www.festo.com](http://www.festo.com)

### Adjusting kit EADC

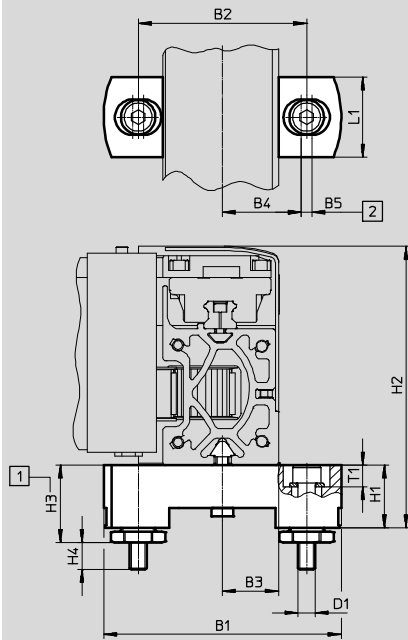

- 1 Adjustable
- 2 Width of hole

Height differences of up to 5 mm can be compensated using the adjusting kit.

Can be ordered via:  
Modular product system → page 32  
Or accessories → page 34

For size	B1	B2	B3	B4 ±0.2	B5	D1	H1	H2	H3		H4 Max.	L1	T1
									Min.	Max.			
40	110	78	26	36.5	5	M8	29	129.8	34.8	39.8	14	37	10
60	130	98	36.5	46.5	5	M8	29	149.1	34.8	39.8	14	37	10

### Mounting kit

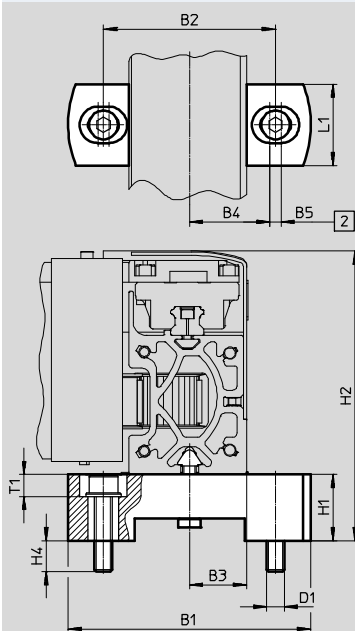

- 2 Width of hole
- No compensation is possible using the mounting kit.

Can be ordered via:  
Modular product system → page 32  
Or accessories → page 34

For size	B1	B2	B3	B4 ±0.2	B5	D1	H1 +0.2	H2	H4 Max.	L1	T1
40	110	78	26	36.5	5	M8	30	131.3	14	37	10
60	130	98	36.5	46.5	5	M8	30	150.1	14	37	10

# Planar surface gantries EXCH

Technical data

Allocation of planar surface gantry to servo motor for X-/Y-axis	
Planar surface gantry	Motor
EXCH-40-...-AB1	EMMS-AS-70-M-LS-RMB
EXCH-40-...-AS1	EMMS-AS-70-M-LS-RM
EXCH-40-...-AB2 <sup>1)</sup>	EMMS-AS-100-S-HS-RMB
EXCH-40-...-AS2	EMMS-AS-100-S-HS-RM
EXCH-60-...-AB2	EMMS-AS-100-M-HS-RMB
EXCH-60-...-AS2	EMMS-AS-100-M-HS-RM
EXCH-60-...-AB3 <sup>1)</sup>	EMMS-AS-140-S-HV-RMB
EXCH-60-...-AS3	EMMS-AS-140-S-HV-RM

1) Essential when the planar surface gantry is mounted vertically.

Allocation of planar surface gantry to servo motor for Z-axis	
Planar surface gantry	Motor
EXCH-40-...-E1	EMMS-AS-40-M-LS-TMB
EXCH-40-...-E2	EMMS-AS-40-M-LS-TMB
EXCH-60-...-E1	EMMS-AS-55-M-LS-TMB
EXCH-60-...-E2	EMMS-AS-55-M-LS-TMB

 Note

Third-party motors with a driving torque that is too high can damage the planar surface gantry. When selecting the motors, please observe the limits specified in the technical data. During commissioning, the motor brake must be released for safety purposes.

Combinations of motor and motor controller			
Planar surface gantry	Order code (→ page 32) for		
	Motor type for X-/Y-axis	Attachment component for Z-axis	Motor controller
EXCH-40-...	AB1, AS1	P1, P2, P3	2x CMMP-AS-C5-3A
		E1, E2	2x CMMP-AS-C5-3A, 1 or 2x CMMP-AS-C2-3A, for front unit (for each electric axis)
	AB2, AS2	P1, P2, P3	2x CMMP-AS-C5-11A-P3
		E1, E2	2x CMMP-AS-C5-11A-P3, 1 or 2x CMMP-AS-C2-3A, for front unit (for each electric axis)
EXCH-60-...	AB2, AS2	P1, P2, P3, P4	2x CMMP-AS-C5-11A-P3
		E1, E2	2x CMMP-AS-C5-11A-P3, 1 or 2x CMMP-AS-C2-3A, for front unit (for each electric axis)
	AB3, AS3	P1, P2, P3, P4	2x CMMP-AS-C5-11A-P3
		E1, E2	2x CMMP-AS-C5-11A-P3, 1 or 2x CMMP-AS-C2-3A, for front unit (for each electric axis)

 Note

The motor controller must be ordered separately as an accessory → page LEERER MERKER. Control system on request.

# Planar surface gantries EXCH

Ordering data – Modular products



Ordering table					
Size	40	60	Conditions	Code	Entry code
<b>M</b> Module no.	<b>1923050</b>	<b>1939785</b>			
Product type	EXCH series H			<b>EXCH</b>	EXCH
Size	40	60		-...	
Stroke of the X-axis [mm]	200 ... 2000	500 ... 2500			
Stroke of the Y-axis [mm]	200 ... 1000	500 ... 1500			
Guide	Recirculating ball bearing guide			<b>-KF</b>	-KF
Motor type	Servo motor, size 70, with brake	-	<b>1</b>	<b>-AB1</b>	
	Servo motor, size 100, with brake	-	<b>3</b>	<b>-AB2</b>	
	-	Servo motor, size 140, with brake	<b>2</b> <b>3</b>	<b>-AB3</b>	
	Servo motor, size 70	-	<b>1</b>	<b>-AS1</b>	
	Servo motor, size 100	-		<b>-AS2</b>	
	-	Servo motor, size 140	<b>2</b>	<b>-AS3</b>	
	Without motor	-	<b>4</b>	<b>-W</b>	
	Motor attachment position	Bottom			
	Top			<b>-T</b>	
Energy chain connection side	Left-hand			<b>-L</b>	-L
Attachment components	None			<b>-T0</b>	
	Electric lifter, 100 mm stroke			<b>-E1</b>	
	Electric lifter, 200 mm stroke			<b>-E2</b>	
	Pneumatic lifter, 50 mm stroke			<b>-P1</b>	
	Pneumatic lifter, 100 mm stroke			<b>-P2</b>	
	Pneumatic lifter, 150 mm stroke			<b>-P3</b>	
	-	Pneumatic lifter, 200 mm stroke		<b>-P4</b>	

- 1 AB1, AS1** Not in combination with size 60
- 2 AB3, AS3** Not in combination with size 40
- 3 AB2, AB3** Essential in the case of a vertical mounting position  
EXCH-40: AB2, EXCH-60: AB3
- 4 W** Not in combination with C, CC, CS, C2, B (operator unit)

Note

In combination with feature W (without motor), the planar surface gantry EXCH is delivered without coupling housing and without coupling.

- M** Mandatory data
- O** Options

**Transfer order code**

**EXCH** -  -  -  - **KF** -  -  - **L** -



# Planar surface gantries EXCH

Ordering data – Modular product system



Ordering table					
Size	40	60	Conditions	Code	Entry code
O Cable length	None			-	
	With cable length 5 m			-5K	
	With cable length 10 m			-10K	
Mounting kit	With adjusting kit				
	With mounting kit			-P	
M Document language	German			-DE	
	English			-EN	
	Spanish			-ES	
	French			-FR	
	Italian			-IT	
	Russian			-RU	
	Chinese			-ZH	

Transfer order code

-  -  -

# Planar surface gantries EXCH

Accessories



## Sensor mounting EAPR

For proximity sensor  
SIES-V3B and SIES-Q8B  
(for sensing the slide position on the X-axis)

Materials:

Switch lug: Steel

Sensor bracket: Wrought aluminium alloy

RoHS-compliant

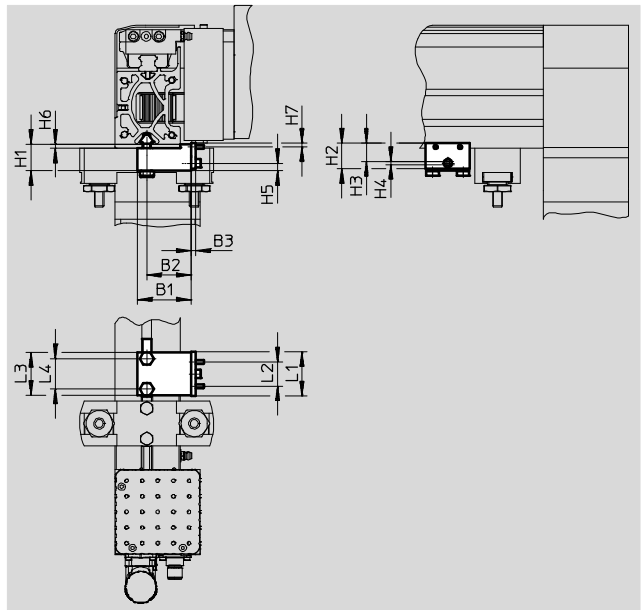

Dimensions and ordering data										
For size	B1	B2	B3	H1	H2	H3 ±0.1	H4	H5	H6 -0.1	H7 -0.2
40	44	36.3	4	21.8	21	15	2.5	6.1	3.1	3
60	54	46.3	4	21	21	15	2.5	5.3	2.3	3

For size	L1	L2	L3	L4	Weight [g]	Part No.	Type
40	36	20	35	25	120	2536353	EAPR-E12-40
60	36	20	35	25	150	2478805	EAPR-E12-60

Ordering data				
	For size	Description	Part No.	Type
<b>Adjusting kit EADC</b>				
	40	For mounting and aligning the planar surface gantry.	8029165	EADC-E12-40
	60	The kit is height-adjustable	8029166	EADC-E12-60
<b>Mounting kit EAHM</b>				
	40	For mounting the planar surface gantry.	3489340	EAHM-E12-K-40
	60	The kit is not height-adjustable	3489318	EAHM-E12-K-60

# Planar surface gantries EXCH

Accessories

FESTO

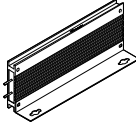
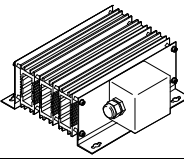
Ordering data						
	For type	Resistance value [Ω]	Nominal power [W]	Weight [g]	Part No.	Type
Braking resistor CACR (Essential in the case of a vertical mounting position)						
	EXCH-...-B1/B2/B3	50	200	550	2882342	CACR-LE2-50-W500
	EXCH-...-B6/B7/B8	40	800	2400	2882343	CACR-KL2-40-W2000

## Permissible proximity sensor for sensing the position of the slide on the Y-axis

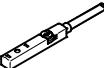
Ordering data – Proximity sensor for T-slot, inductive						Technical data → Internet: sies
	Type of mounting	Electrical connection	Switching output	Cable length [m]	Part No.	Type
	Inserted in the slot from above, flush with the cylinder profile	Plug connector M8x1, 3-pin	PNP, N/O contact	0.3	551387	SIES-8M-PS-24V-K-0,3-M8D

## Permissible proximity sensors for sensing the positions on the Z-axis

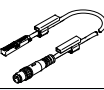
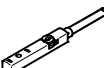
Ordering data – Proximity sensors for T-slot						Technical data → Internet: smt
	Type of mounting	Electrical connection	Switching output	Cable length [m]	Part No.	Type
With mini slide DGSL (magneto-resistive)						
	Inserted in the slot from above, flush with the cylinder profile	Plug connector M8x1, 3-pin	PNP, N/O contact	0.3	551367	SME-10M-DS-24V-E-0,3-L-M8D
With mini slide EGSL (inductive)						
	Inserted in the slot from above, flush with the cylinder profile	Plug connector M8x1, 3-pin	PNP, N/O contact	0.3	551387	SIES-8M-PS-24V-K-0,3-M8D

## Permissible proximity sensors in combination with sensor mounting EAPR-E12

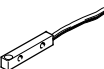
Ordering data – Proximity sensors					Technical data → Internet: sies
	Type of mounting	Electrical connection	Switching output	Part No.	Type
N/O contact					
	Screwed on	Plug connector M8x1, 3-pin	PNP	150491	SIES-V3B-PS-S-L
N/C contact					
	Screwed on	Cable, 3-wire	NPN	174550	SIES-Q8B-NO-K-L

# Planar surface gantries EXCH

Accessories

FESTO

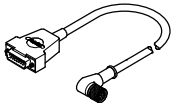
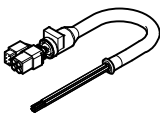
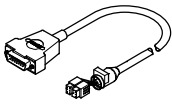
Ordering data – Cables					
	Description	Cable length [m]	Part No.	Type	
For X-/Y-axis					
	Motor cable NEBM – Min. bending radius: 64 mm – Suitable for use with energy chains – Ambient temp.: –40 ... +90 °C	5	550310	NEBM-M23G8-E-5-Q9N-LE8	
		10	551311	NEBM-M23G8-E-10-Q9N-LE8	
	Encoder cable NEBM – Min. bending radius: 75 mm – Suitable for use with energy chains – Ambient temp.: –10 ... +80 °C	5	550318	NEBM-M12W8-E-5-N-S1G15	
		10	550319	NEBM-M12W8-E-10-N-S1G15	
For Z-axis					
	Motor cable NEBM – Min. bending radius: 55 mm – Suitable for use with energy chains – Ambient temp.: –40 ... +90 °C	10	550307	NEBM-T1G8-E-10-Q7N-LE8	
		15	551308	NEBM-T1G8-E-15-Q7N-LE8	
	Encoder cable NEBM – Min. bending radius: 75 mm – Suitable for use with energy chains – Ambient temp.: –10 ... +80 °C	10	550315	NEBM-T1G8-E-10-N-S1G15	
		15	550316	NEBM-T1G8-E-15-N-S1G15	

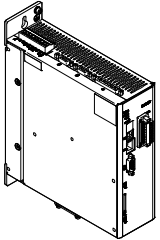
Ordering data – Motor controller						
	For size	Output voltage	Nominal output current	Nominal power	Part No.	Type
		[V AC]	[A]	[VA]		
	For linear gantry					
	40	3x 0 ... 270	5	1000	1622902	CMMP-AS-C5-3A-M0
	40, 60	3x 0 ... 360	5	3000	1622903	CMMP-AS-C5-11A-P3-M0
	For attachment components					
40, 60	3x 0 ... 270	2.5	500	1622901	CMMP-AS-C2-3A-M0	

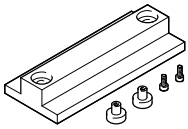
Ordering data				
	For size	Description	Part No.	Type
Adjusting tool EADT				
	40, 60	For aligning and checking the levelness of the planar surface gantry	3197697	EADT-W-E12

# Festo North America

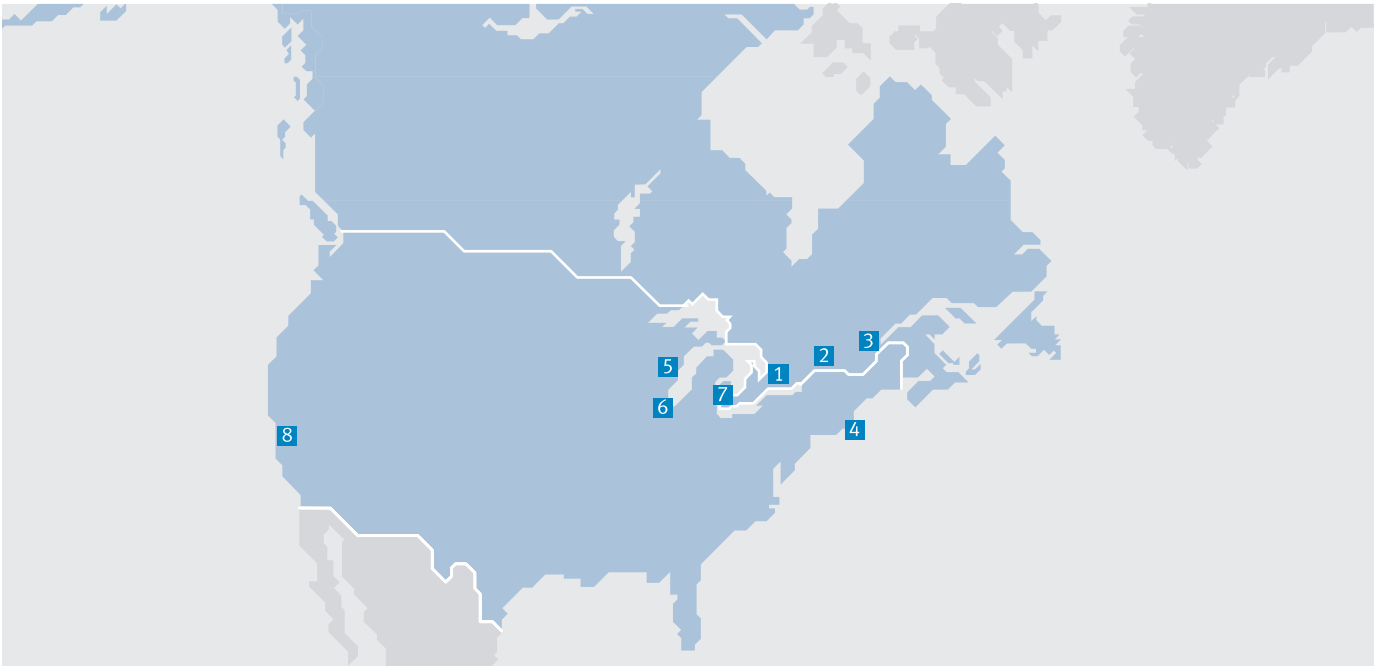

**1 Festo Canada  
Headquarters  
Festo Inc.**  
5300 Explorer Drive  
Mississauga, ON  
L4W 5G4

**2 Montréal**  
5600, Trans-Canada  
Pointe-Claire, QC  
H9R 1B6

**3 Québec City**  
2930, rue Watt#117  
Québec, QC  
G1X 4G3



**4 Festo United States  
Headquarters  
Festo Corporation**  
395 Moreland Road  
Hauppauge, NY  
11788

**5 Appleton**  
North 922 Tower View Drive, Suite N  
Greenville, WI  
54942

**7 Detroit**  
1441 West Long Lake Road  
Troy, MI  
48098

**6 Chicago**  
85 W Algonquin - Suite 340  
Arlington Heights, IL  
60005

**8 Silicon Valley**  
4935 Southfront Road, Suite F  
Livermore, CA  
94550

## Festo Regional Contact Center

### Canadian Customers

Commercial Support:  
Tel: 1 877 GO FESTO (1 877 463 3786)  
Fax: 1 877 FX FESTO (1 877 393 3786)  
Email: festo.canada@ca.festo.com

Technical Support:  
Tel: 1 866 GO FESTO (1 866 463 3786)  
Fax: 1 877 FX FESTO (1 877 393 3786)  
Email: technical.support@ca.festo.com

### USA Customers

Commercial Support:  
Tel: 1 800 99 FESTO (1 800 993 3786)  
Fax: 1 800 96 FESTO (1 800 963 3786)  
Email: customer.service@us.festo.com

Technical Support:  
Tel: 1 866 GO FESTO (1 866 463 3786)  
Fax: 1 800 96 FESTO (1 800 963 3786)  
Email: product.support@us.festo.com